

Hydraulic Power Units

D, H, V-Pak and V-Pak Low Profile Series

HY28-2661-CD/US

Effective: Mar 31, 2016



ENGINEERING YOUR SUCCESS.



WARNING - USER RESPONSIBILITY

FAILURE OR IMPROPER SELECTION OR IMPROPER USE OF THE PRODUCTS DESCRIBED HEREIN OR RELATED ITEMS CAN CAUSE DEATH, PERSONAL INJURY AND PROPERTY DAMAGE.

This document and other information from Parker-Hannifin Corporation, its subsidiaries and authorized distributors provide product or system options for further investigation by users having technical expertise.

The user, through its own analysis and testing, is solely responsible for making the final selection of the system and components and assuring that all performance, endurance, maintenance, safety and warning requirements of the application are met. The user must analyze all aspects of the application, follow applicable industry standards, and follow the information concerning the product in the current product catalog and in any other materials provided from Parker or its subsidiaries or authorized distributors.

To the extent that Parker or its subsidiaries or authorized distributors provide component or system options based upon data or specifications provided by the user, the user is responsible for determining that such data and specifications are suitable and sufficient for all applications and reasonably foreseeable uses of the components or systems.

OFFER OF SALE

The items described in this document are hereby offered for sale by Parker-Hannifin Corporation, its subsidiaries or its authorized distributor. This offer and its acceptance are governed by the provisions stated in the detailed "Offer of Sale" elsewhere in this document.

Contents

D, H and V-Pak Series

Introduction	2-3
Ordering Information.....	4-10
Installation Information	11-13
Technical Information	14-30

H-Pak with DCP

Introduction	32-33
Ordering Information.....	6-8
Installation Information	27
Safety & Technical Information.....	34-40

V-Pak Low Profile Series

Introduction	42-43
Ordering Information.....	44-45
Installation Information	46
Technical Information	47-58

Additional Installation Information	59
---	----

Additional Technical Information	60
--	----

Conversion Equations.....	61
---------------------------	----

Offer of Sale	63
---------------------	----



Quick Reference Data Chart

Pump Model No.	Tank Size Liters (Gallon)	Pump Flow LPM (GPM) @ 1725 RPM	Electrical Motors KW (HP)	Maximum* Bar (PSI)
D-Paks	18.9 (5)	3.4 - 10.2 (0.9 - 2.7)	0.37 (0.5) - 2.24 (3)	207 (3000)
H-Paks	37.9 (10), 75.7 (20), 113.6 (30), 151.4 (40)	3.4 - 36.3 (0.9 - 9.6)	0.37 (0.5) - 14.9 (20)	207 (3000)
V-Paks	37.9 (10), 75.7 (20), 113.6 (30), 151.4 (40)	7.6 - 59.1 (2.0 - 15.6)	1.5 (2) - 14.9 (20)	207 (3000)
V8	302.8 (80)	41.6 - 136.7 (11.0 - 36.1)	5.6 - 30 (7 1/2 - 40)	207 (3000)

* See pump/motor combination, maximum pressure charts.

Warranty

The hydraulic components on these Parker Power Units are warranted for one year. This warranty may be extended to two years by using and properly maintaining Parker filters.

Installation Data:

See Installation/Maintenance Manual for specific recommendations pertaining to start-up, system cleanliness, fluids, temperature and other important factors relative to proper installation and use of these power units.



Standard Features

- Vertical Design
- Submerged Pump
- Spare Return Ports
- Precision Pump Mounting Adapters
- Suction Strainer
- Glycerine Filled Pressure Gage with Shut Off
- Oil Level Gage with Thermometer
- Relief Valve
- Breather and Fill Cap
- SAE Drain Plug
- Parker Connector Technology
- Available with Digital Drives
 (See DCP Pak section of this catalog)

Benefits

- Saves Floor Space
- Quieter Operation, Elimination of Potential Leak Point
- Longer Pump Life
- Protects Pump from Contamination
- Improved Diagnostics
- Helps to Maintain Trouble-Free Performance
- Protects Against System Shock
- Easy To Fill Reservoir
- Prevents Leaks

Schematic Symbol

(Hydraulic Schematic - Basic Unit)

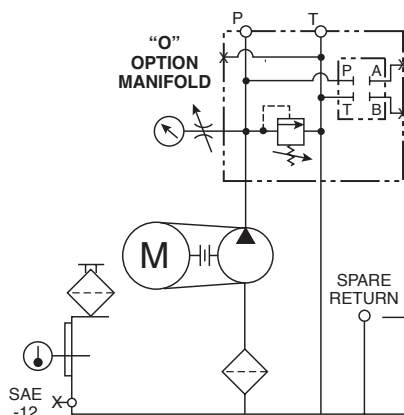

D & H-PAK BASIC UNIT
 NO OPTIONS OR ACCESSORIES
 "O" OPTION MANIFOLD

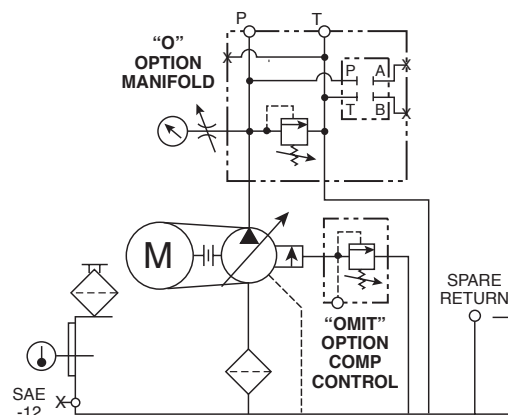

V-PAK BASIC UNIT
 NO OPTIONS OR ACCESSORIES
 "OMIT" OPTION PUMP COMPENSATOR
 "O" OPTION MANIFOLD

D-Paks Ordering Information



Reservoir
18.9 Liters
(5 Gal)



Pressure Control



Pump Flow



D = Dual Rated*
W = No Motor**
Electric Motor



Manifold



Directional Control Valve



Manapak Control Valves*



Options and Accessories

Code	Pressure Control
Omit	System Pressure Relief Valve Only
B	System Pressure Relief Valve with Unloading Valve (2-Way 120VAC) N.O. (Energize coil to close)
J	System Pressure Relief Valve with Unloading Valve (2-Way 24VDC) N.O. (Energize coil to close)

Code	Pump Flow Used
0.9	331-9110-267
1.3	331-9110-011
1.8	331-9110-010
2.7	331-9110-101

If No Motor or Dual Rated	Code	Electric Motor Description HP (KW) - RPM Frame Phase
	U1	.5 (.37) - 1725-56C-1
	T1	1 (.75) - 1725-56C-1
	T3	1 (.75) - 1725-56C-3
W	G	56C (no motor)
D	G	2 (1.5)-1725 - 56C-3*
D	K	3 (2.2) - 1725-182TC*
W	L	182TC/184TC (no motor)

D = DUAL RATED *
W = NO MOTOR **

Single phase electric motors are rated as follows:
115/230V, 1PH, TEFC - 60 Hertz 1800 RPM

Three phase electric motors are rated as follows:
208-230/460V, 3PH, TEFC - 60 Hertz 1800 RPM 1.15 SF

* Dual rated motors include the 60Hz ratings plus 190/380V 50Hz (1.5SF) 1450RPM 10:1CT/20:1VT INVERTER RATED UR/CSA/CSA EEV/CE

* Options G & K are dual rated as standard.

** Use W prefix when no motor is required on unit.
When ordering, W must be followed by motor model code equivalent to frame size of motor to be used.

DO NOT USE "W" and "D" together i.e. 56C frame unit with no motor is called out "WG".

Code	Porting Block/Subplate or Manifold Type	Supply/Return Port or Actuator Port Size	Other
O	Pressure and Return Port Block with Safety Relief Valve	P & T Ports SAE-10 Str. Thr'd	Convertible to S3 Option
S3	D03 Single Station Subplate with Safety Relief Valve	A & B Ports SAE-8 Str. Thr'd	Spare P & T SAE-10 Ports
M33	D03 Multistation Parallel Circuit Manifold with Safety Relief Valve	A & B Ports SAE-8 Str. Thr'd	Spare G Port SAE-6

Manifolds are mounted vertically. Bottom station is number 1.

= Omit if not required

Code	Directional Control Valve Model Number	NFPA Mounting Pad	Nominal Flow GPM (LPM)	Description	Circuit Symbol
B	D1VW001CN***	D03	7 (26.5)	Double (Spr. Ctr)	
C	D1VW004CN***	D03	7 (26.5)	Double (Spr. Ctr)	
T	D1VW008CN***	D03	7 (26.5)	Double (Spr. Ctr)	

Units less valves will be supplied with station cover plates installed.

Code	Manapak Control Valves Function	Valve Model Number	NFPA Mounting Pad	Nominal Flow GPM (LPM)	Circuit Symbol
1	Flow Control Meter-Out	FM2DDKN	D03	7 (26.5)	
3	Pilot Operator Check	CPOM2DDN	D03	7 (26.5)	

Manapak valves mounted in order of callout.
First valve will be nearest DCV; last valve will be on manifold.

Code	Options and Accessories		
	Function	Model Number	Technical Data
B1*	Exchanger	RM-08-2-2	Air/Oil: 0.7 HP (52 kW) Rej. @ 3 GPM (11.4 LPM)
H	Pressure Filter	15P110QXRS	Microglass II Element Vis. Ind. - 50 PSI (3.4 bar) Bypass - 2 PSI (0.14 bar) Diff. @ 3 GPM (11.4 LPM)
K	Check Valve Pump Outlet	DT370MOMF05	5 PSI (0.34 bar) Cracking Pressure 7 PSI (0.48 bar) Diff. @ 3 GPM (11.4 LPM)
L	Bypass Check (on Heat Exch)	C1020S65	65 PSI (4.5 bar) Cracking Pressure
O	Return Filter	12AT10C 45LPM (12 GPM)	Cellulose Element Ind. Gage - 15 PSI (1.03 bar) Bypass Max. Oil Flow
R1	Combination Float/Temp. Switch N.O. Float Up	8767820-1	Fixed Temp at 65°C (149°F) Close @ Low Level and/or 65°C (149°F) (N.C.)
R2	Combination Float/Temp. Switch Float Up	876782-02	Fixed Temp at 65°C (149°F) Open @ Low Level and/or 65°C (149°F) (N.C.)

*Heat rejection based on flow given with a 40°F differential between transfer medium.





Reservoir



Pressure Control



Pump Flow

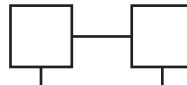

D = Dual Rated*
W = No Motor** Electric Motor



Manifold

Code	Reservoir Size Gallons (Liters)
H1*	10 (37.9)
H2	20 (75.7)
H3	30 (113.6)
H4	40 (151.4)

*Available up to 7.5 KW (10 HP) motor only.

Code	Pressure Control*
Omit	System Pressure Relief Valve Only
B	System Pressure Relief Valve with Unloading Valve (2-Way 120VAC) N.O. (Energize coil to close)
J	System Pressure Relief Valve with Unloading Valve (2-Way 24VDC) N.O. (Energize coil to close)

Code	Pump Flow Used
0.9	331-9110-267
1.3	331-9110-011
1.8	331-9110-010
2.7	331-9110-101
3.2	334-9111-069
4.5	334-9111-068
5.1	334-9111-067
6.3	334-9111-048
8.1*	334-9111-065
9.6*	334-9111-049

*Do not select a motor smaller than 2 Hp with these flow rates.

If No Motor or Dual Rated	Code	Electric Motor Description HP (KW) - RPM Frame Phase
	U1	.5 (.37) - 1725-56C-1
	T1	1 (.75) - 1725-56C-1
	T3	1 (.75) - 1725-56C-3
W	G	56C (no motor)
D	G	2 (1.5)-1725 - 56C-3 DUAL RATED
D	K	3 (2.2) - 1725-182TC DUAL RATED
W	L	182TC/184TC (no motor)
	L	5 (3.75) - 1725 - 184TC - 3
D	L	5 (3.75) - 1725 - 184TC - 3 DUAL RATED
W	M	213TC (no motor)
	M	7.5 (5.6) - 1725 - 213TC - 3
D	M	7.5 (5.6) - 1725 - 213TC - 3 DUAL RATED
W	N	215TC (no motor)

Continued: top right.

= Omit if not required

If No Motor or Dual Rated	Code	Electric Motor Description HP (KW) - RPM Frame Phase
	N	10 (7.5) - 1725 - 215TC - 3
D	N	10 (7.5) - 1725 - 215TC - 3 DUAL RATED
W	P †	254TC (no motor)
	P †	15 (11.2) - 1725 - 254TC - 3
D	P †	15 (11.2) - 1725 - 254TC - 3 DUAL RATED
W	S †	256TC (no motor)
	S †	20 (14.9) - 1725 - 256TC - 3
D	S †	20 (14.9) - 1725 - 256TC - 3 DUAL RATED

Single phase electric motors are rated as follows:
115/230V, 1PH, TEFC - 60 Hertz 1800 RPM

Three phase electric motors are rated as follows:
208-230/460V, 3PH, TEFC - 60 Hertz 1800 RPM 1.15 SF

* Dual rated motors include the 60Hz ratings plus 190/380V 50Hz (1.0SF) 1450RPM 10:1CT/20:1VT INVERTER RATED UR/CSA/CSA EEV/CE. 2Hp & 3Hp S.F.=1.15

* Dual rated motors except 2Hp & 3Hp may have longer than standard leadtime. Options G & K are dual rated as standard.

Consult factory for other motor speeds (RPM) and voltages.

†Available with H2, H3 and H4 tanks only.

** Use W prefix when no motor is required on unit.

When ordering, W must be followed by motor model code equivalent to frame size of motor to be used.

DO NOT USE "W" and "D" together i.e.: 182/184TC unit with no motor is called out "WL".

Code	Porting Block/ Subplate or Manifold Type	Supply/Return Port or Actuator Port Size	Other
O	Pressure and Return Port Block with Safety Relief Valve	P & T Ports SAE-10 Str. Thr'd	Convertible to S3 Option
S3	D03 Single Station Subplate with Safety Relief Valve	A & B Ports SAE-8 Str. Thr'd	Spare P & T SAE-10 Ports
S5	D05 Single Station Subplate with Safety Relief Valve	A & B Ports SAE-10 Str. Thr'd	Spare P & T SAE-12 Ports
M33 M35	D03 Multistation Parallel Circuit Manifold with Safety Relief Valve	A & B Ports SAE-8 Str. Thr'd	Spare G Port SAE-6
M53 M55	D05 Multistation Parallel Circuit Manifold with Safety Relief Valve	A & B Ports SAE-8 Str. Thr'd	Spare G Port SAE-6

Manifolds are mounted vertically. Bottom station is number 1.

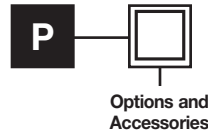

For DCP (inverter) options, see next page

Code	Valve Model Number	NFPA Mounting Pad	Nominal Flow GPM (LPM)	Description	Circuit Symbol
B	D1VW001CN***	D03	7 (26.5)	Double (Spr. Ctr)	
C	D1VW004CN***	D03	7 (26.5)	Double (Spr. Ctr)	
F	D3W1CN**	D05	20 (75.7)	Double (Spr. Ctr)	
G	D3W4CN**	D05	15 (56.8)	Double (Spr. Ctr)	
T	D1VW008CN***	D03	7 (26.5)	Double (Spr. Ctr)	
W	D3W8CN**	D05	15 (56.8)	Double (Spr. Ctr)	

Units less valves will be supplied with station cover plates installed.

Code	Function	Valve Model Number	NFPA Mounting Pad	Nominal Flow GPM (LPM)	Circuit Symbol
1	Flow Control	FM2DDKN	D03	7 (26.5)	
2	Flow Control	FM3DDKN	D05	12 (45.4)	
3	Pilot Operator Check	CPOM2DDN	D03	7 (26.5)	
4	Pilot Operator Check	CPOM3DDN	D05	12 (45.4)	

*Manapak valves mounted in order of callout. First valve will be nearest DCV; last valve will be on manifold.

Code	Function	Model Number	Technical Data
B1*	Return Line Heat Exchanger	RM-08-1-2	Air/Oil: .7 HP (0.52 kW), Rej. @ 7 GPM (26.5 LPM) 0.37 - 3.7 kW Motors only
B2*	Return Line Heat Exchanger	RM 190-1-2	Air/Oil: 1.5 HP (1.1 kW), Rej. @ 7 GPM (26.5 LPM) 5.6 - 11.2 kW Motors only
C ^	Return Line Heat Exchanger	BS-401-A4-O-BR	Water/oil: 4hP (3KW)Rej @ 5GPM Oil Flow 1:1 Flow ratio Max oil Flow 10GPM Includes 3/4" weld coupling for customer supplied device
E^	Water Valve/bulbwell	65253 + bulbwell + 3/4" weld coupling	If ordered without option C this option will only include the 3/4" weld coupling.
H	Pressure Filter	15P110QXRS	Microglass II Element, Vis. Ind. - 50 PSI (3.49 bar) Bypass - 4 PSI (0.27 bar), Diff. @ 7 GPM (26.5 LPM)
J	2" Weld coupling for customer supplied heater		
K	Check Valve Pump Outlet	"DT" & "C" Series	5 PSI (0.34 bar) Cracking Pressure 25 PSI (1.72 bar) Diff. @ 15 GPM (56.8 LPM)
L	Bypass Check (on Heat Exch)	C1220S65	(65 PSI) 4.5 bar Cracking Pressure
N	Return Filter	40CN110B	MICROGLASS ii Element, Vis 25PSI (1.72Bar) Indicator 3PSI (0.21Bar) Diff. @ 7GPM (26.5LPM)
O	Return Filter	12AT10C 12 GPM (45 LPM)	Cellulose Element, Ind. Gage - 15 PSI (1.03 bar) Bypass
R1	Combination Float/Temp. Switch N.O. Float Up	876782-01	Fixed Temp at 65°C (149°F) Close @ Low Level and/or 65°C (149°F) (N.O.)
R2	Combination Float/Temp. Switch Float Up	876782-02	Fixed Temp at 65°C (149°F) Open @ Low Level and/or 65°C (149°F) (N.C.)

= Omit if not required

*Heat rejection based on flow given with a 40°F differential between transfer medium.
^ May require longer than standard lead time.

From H-Pak
Options &
Accessories

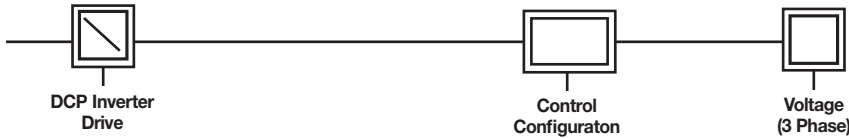

Code	Configuration
Omit	End of Model Code
\	AC10 Drive configured per the following selections

DCP Option Not Available on 1/2 & 1 Hp Units

Code	Configuration	Description
I	Analog Speed Control (4-20mA)	Unit will be configured to operate 500-2000 RPM from a 4-20mA input signal
V	Analog Speed Control (0-10VDC)	Unit will be configured to operate 500-2000 RPM from a 0-10VDC input signal
D	Discrete Speed Control (3 inputs)	Unit will be configured to operate at 8 discrete speeds based on combination of 3 inputs.
Q	2 Speeds Based on Torque	Unit will run at 1800 RPM until motor torque Reaches 85% of NOM, them will go to 600 RPM.
S	Soft Start	Unit will be configured to run at 1800 RPM with a 2 sec accel ramp (0 to 1800 RPM in 2 secs)

Code	Configuration	Description
2*	Incoming Power 230VAC 3 Phase	220-240V +/-15%
4	Incoming Power 460VAC 3 Phase	380-480V +/-10%/-15%

*Only available for 2Hp & 3Hp Drives
Consult factory for single phase applications

Sample Model Code
H36.3NOPHKNV4

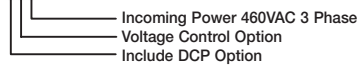

HP	Voltage	Hp/Voltage	AC 10 Part Numbers
2	2	Incoming Power 230VAC 3 Phase	16G-31-0070-BF-DT
	4	Incoming Power 460VAC 3 Phase	16G-41-0040-BF-DT
3	2	Incoming Power 230VAC 3 Phase	16G-31-0100-BF-DT
	4	Incoming Power 460VAC 3 Phase	16G-41-0065-BF-DT
5	4	Incoming Power 460VAC 3 Phase	16G-41-0090-BF-DT
7.5	4	Incoming Power 460VAC 3 Phase	16G-42-0120-BF-DT
10	4	Incoming Power 460VAC 3 Phase	16G-42-0170-BF-DT
15	4	Incoming Power 460VAC 3 Phase	16G-43-0230-BF-DT
20	4	Incoming Power 460VAC 3 Phase	16G-43-0320-BF-DT

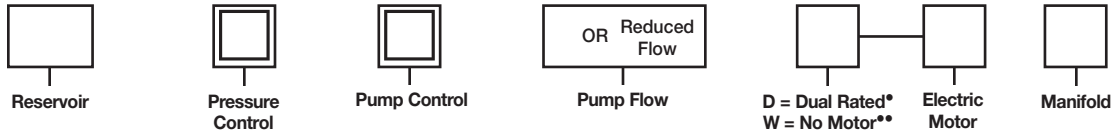

Code	Reservoir Size Gallons (Liters)
V1*	10 (37.9)
V2	20 (75.7)
V3	30 (113.6)
V4	40 (151.4)

*Available up to 10 HP (7.5 kW) motor only.

Code	Pressure Control
Omit	Single Pressure Remote Compensator
B	Single Pressure Remote Compensator with Low Pressure Standby
BJ	Single Pressure Remote Compensator with Low Pressure Standby, 24 VDC
C	Bi-Pressure Remote Compensator
CJ	Bi-Pressure Remote Compensator, 24VDC
D	Bi-Pressure Remote Compensator with Low Pressure Standby
DJ	Bi-Pressure Remote Compensator with Low Pressure Standby, 24VDC
F	Provision for Customer Supplied Remote Control Relief Valve

Code	Pump Control
Omit	Std. Remote Compensator
A*	Load Sense Flow Control
H**	Horsepower Limiting

*A SAE-6 sense port line will be supplied in topplate.

** Horsepower setting will be at max. flow & pressure obtainable with motor selected. Lead time is four weeks for shaded items.

Code	Pump Flow Rate @1800 RPM	Pump Used and Description
7	7 GPM (29.5 LPM)	PVP16 - Std. Remote Compensator
*	Specify in GPM	Destroyed Max. Volume – 2 GPM Min.
15	15.6 GPM (59 LPM)	PVP33 - Std. Remote Compensator
**	Specify in GPM	Destroyed Max. Volume – 8 GPM Min.

*Unless otherwise specified, units are shipped at max. flow rate 7.8 GPM (29.5 LPM) at 1800 RPM. When reduced flow setting is required, specify pump setting in .5 GPM (1.9 LPM) increments. Example: 5, 5.5, 6, 6.5 with a 2 GPM (7.6 LPM) minimum flow.

**Unless otherwise specified, units are shipped at max. flow rate 15.6 GPM (59 LPM) at 1800 RPM. When reduced flow setting is required, specify pump setting in .5 GPM (1.9 LPM) increments. Example: 11, 11.5, 12, 12.5 with a 8 GPM (30.3 LPM) minimum flow.

Example: V*12**-- = Std. Pump Destroyed to 12 GPM (45.4 LPM)
V*A11.5**-- = Load Sense Pump Destroyed to 11.5 GPM (43.5 LPM)

= Omit if not required

If No Motor or Dual Rated	Code	Electric Motor Description HP (KW) - RPM Frame Phase
W	G	56C (no motor)
D	G	2 (1.5)-1725 - 56C-3 DUAL RATED
D	K	3 (2.2) - 1725-182TC DUAL RATED
W	L	182TC/184TC (no motor)
	L	5 (3.75) - 1725 - 184TC - 3
D	L	5 (3.75) - 1725 - 184TC - 3 DUAL RATED
W	M	213TC (no motor)
	M	7.5 (5.6) - 1725 - 213TC - 3
D	M	7.5 (5.6) - 1725 - 213TC - 3 DUAL RATED
W	N	215TC (no motor)
	N	10 (7.5) - 1725 - 215TC - 3
D	N	10 (7.5) - 1725 - 215TC - 3 DUAL RATED
W	P †	254TC (no motor)
	P †	15 (11.2) - 1725 - 254TC - 3
D	P †	15 (11.2) - 1725 - 254TC - 3 DUAL RATED
W	S †	256TC (no motor)
	S †	20 (14.9) - 1725 - 256TC - 3
D	S †	20 (14.9) - 1725 - 256TC - 3 DUAL RATED

Single phase electric motors are rated as follows:
115/230V, 1PH, TEFC - 60 Hertz 1800 RPM

Three phase electric motors are rated as follows:
208-230/460V, 3PH, TEFC - 60 Hertz 1800 RPM 1.15 SF

* Dual rated motors include the 60Hz ratings plus 190/380V 50Hz (1.0SF) 1450RPM 10:1CT/20:1VT INVERTER RATED UR/CSA/CSA EEV/CE. 2Hp & 3Hp S.F.=1.15

* Dual rated motors except 2Hp & 3Hp may have longer than standard leadtime. Options G & K are dual rated as standard.

Consult factory for other motor speeds (RPM) and voltages.

† Available with V2, V3 and V4 tanks only.

** Use W prefix when no motor is required on unit.

When ordering, W must be followed by motor model code equivalent to frame size of motor to be used.

DO NOT USE "W" and "D" together I.E: 182/184TC unit with no motor is called out "WL".

Code	Porting Block/Subplate or Manifold Type	Supply/Return Port or Actuator Port Size	Other
O	Pressure and Return Port Block with Safety Relief Valve	P & T Ports SAE-10 Str. Thr'd	Convertible to S5 Option
S3	D03 Single Station Subplate with Safety Relief Valve	A & B Ports SAE-8 Str. Thr'd	Spare P & T SAE-10 Ports
S5	D05 Single Station Subplate with Safety Relief Valve	A & B Ports SAE-10 Str. Thr'd	Spare P & T SAE-12 Ports
M33 M35	D03 Multistation Parallel Circuit Manifold with Safety Relief Valve	A & B Ports SAE-8 Str. Thr'd	Spare G Port SAE-6
M53 M55	D05 Multistation Parallel Circuit Manifold with Safety Relief Valve	A & B Ports SAE-8 Str. Thr'd	Spare G Port SAE-6

Manifolds are mounted vertically. Bottom station is number 1.



Code	Directional Control Valve Model Number	NFPA Mounting Pad	Nominal Flow GPM (LPM)	Description	Circuit Symbol
B	D1VW001CN***	D03	7 (26.5)	Double (Spr. Ctr)	
C	D1VW004CN***	D03	7 (26.5)	Double (Spr. Ctr)	
F	D3W1CN**	D05	20 (75.7)	Double (Spr. Ctr)	
G	D3W4CN**	D05	15 (56.8)	Double (Spr. Ctr)	

Units less valves will be supplied with station cover plates installed.

Code	Manapak Control Valves Function	Valve Model Number	NFPA Mounting Pad	Nominal Flow GPM (LPM)	Circuit Symbol
1	Flow Control	FM2DDKN	D03	7 (26.5)	
2	Flow Control	FM3DDKN	D05	12 (45.4)	
3	Pilot Operator Check	CPOM2DDN	D03	7 (26.5)	
4	Pilot Operator Check	CPOM3DDN	D05	12 (45.4)	

*Manapak valves mounted in order of callout.
First valve will be nearest DCV; last valve will be on manifold.

Code	Options and Accessories		
	Function	Model Number	Technical Data
A*	Pump Case Heat Exchanger	RM-08-4-2	Air/Oil: .7Hp (.52KW) Rej @ .5GPM (1.9LPM) 2-15Hp(1.5 -11.2KW) Motors only
B1*	Return Line Heat Exchanger	RM-08-1-2	Air/Oil: .7Hp (.52KW) Rej @ 7GPM (26.5LPM) 0.37 -3.7KW Motors only
B2*	Return Line Heat Exchanger	RM 190-1-2	Air/Oil: 1.5Hp (1.1KW) Rej @ 7GPM (26.5LPM) 5.6 -14.9 KW Motors only
C*^	Return Line Heat Exchanger	BS-401-A4-O-BR	Water/oil: 4Hp (3KW)Rej @ 5GPM Oil Flow 1:1 Flow ratio Max oil Flow 10GPM Includes 3/4" weld coupling for customer supplied device
D*^	Return Line Heat Exchanger	BS-701-B6-F-BR	Water/oil: 7Hp (5.2KW)Rej @ 15GPM Oil Flow 2:1 Flow ratio Max oil Flow 29GPM Includes 3/4" weld coupling for customer supplied device
E^	Water valve/bulbwell	65253 + bulbwell + 3/4" weld coupling	If ordered without options C or D this option will only include the 3/4" weld coupling.
H	Pressure Filter	15P110QXRS	Microglass II Element, Vis. Ind. - 50 PSI (3.49 bar) Bypass - 4 PSI (0.27 bar), Diff. @ 7 GPM (26.5 LPM)
J	2" Weld coupling for customer supplied heater		
K	Check Valve Pump Outlet	"DT" & "C" Series	5 PSI (0.34 bar) Cracking Pressure 25 PSI (1.72 bar) Diff. @ 15 GPM (56.8 LPM)
L	Bypass Check (on Heat Exch)	C1220S65	(65 PSI) 4.5 bar Cracking Pressure
N	Return Filter	40CN110B	Microglass II Element, Visual 25 PSI (1.72 bar) Indicator 3 PSI (0.21 bar) Diff. @ 7 GPM (26.5 LPM)
O	Return Filter	12AT10C 12 GPM (45 LPM)	Cellulose Element, Ind. Gage - 15 PSI (1.03 bar) Bypass
R1	Combination Float/Temp. Switch N.O. Float Up	876782-01	Fixed Temp at 65°C (149°F) Close @ Low Level and/or 65°C (149°F) (N.O.)
R2	Combination Float/Temp. Switch Float Up	876782-02	Fixed Temp at 65°C (149°F) Open @ Low Level and/or 65°C (149°F) (N.C.)

*Heat rejection based on 40°F differential between transfer medium.
^ May require longer than standard lead time.

= Omit if not required

Dimensions – Basic D-Pak (18.9 Liter (5 Gallon) Tank)

Inch equivalents for millimeter dimensions are shown in (**).

Motor Code	Motor Size	Dimension "B"
U1, T1, T3, DG	56C Frame	0"
DK	182TC Frame	19.1 (.75)

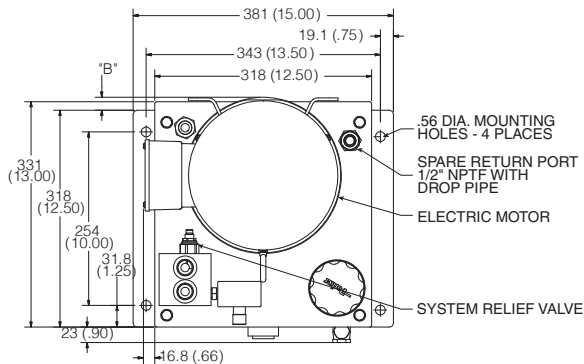

"O" & "S3" OPTION MANIFOLD
 (P & T BLOCK & D03 SINGLE STATION)
 BASIC UNIT

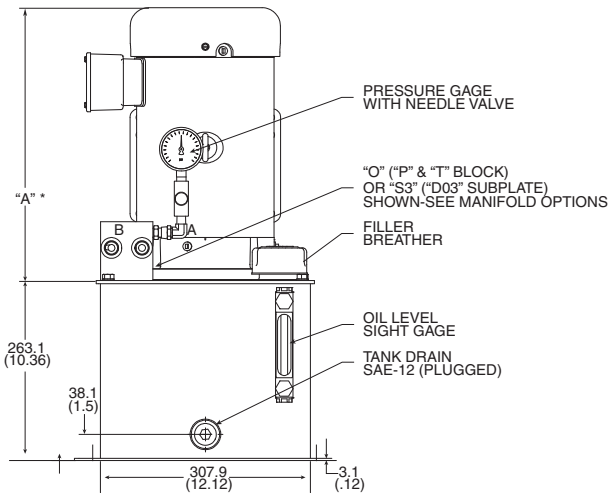

Motor Code	Motor Description KW(HP)-RPM-Frame-Phase	Dimension
		"A" *
U1	.37 (.5)-1725-56C-1	269.75 (10.62)
C1	.56 (.75)-1725-56C-1	295.15 (11.62)
T1	.75 (1)-1725-56C-1	295.15 (11.62)
T3	.75 (1)-1725-56C-3	258.57 (10.18)
F	1.1 (1.5)-1725-56C-3	283.97 (11.18)
G	1.5 (2)-1725-56C-3	306.32 (12.06)
K	2.2 (3)-1725-56C-3	341.37 (13.44)
DG	2(1.5)-1725-56C-3 DUAL RATED	359 (14.1)
DK	3(2.2)-1725-182TC DUAL RATED	435 (17.1)

* Reference dimension consult factory if critical to application.

Filter Option Reference

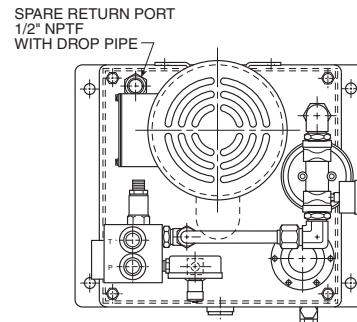

"O" & "S3" OPTION MANIFOLD
 (P & T BLOCK & D03 SINGLE STATION)
 SHOWN WITH OPTION "O" RETURN FILTER

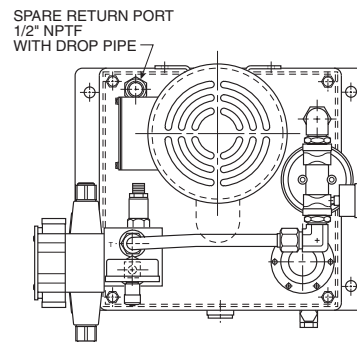
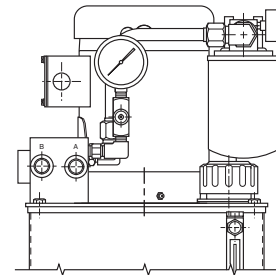

"M3" & "C3" OPTION MANIFOLD
 (MULTI-STATION D03 MANIFOLD)
 SHOWN WITH OPTION "O" RETURN FILTER

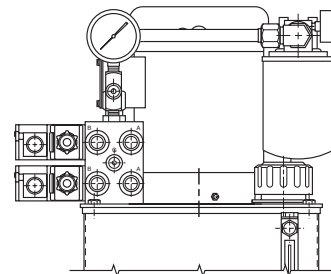

**Dimensions – Basic H1 & V1
 (10 Gallon Tank)**

Inch equivalents for millimeter dimensions are shown in (**).

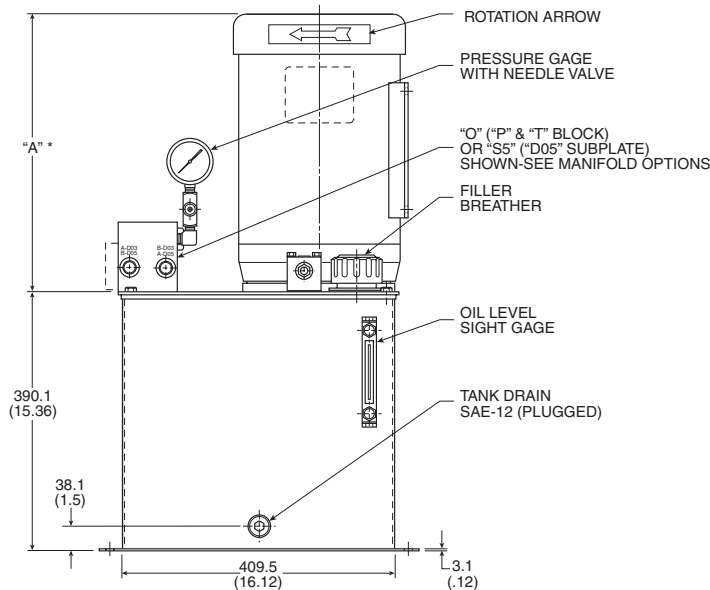
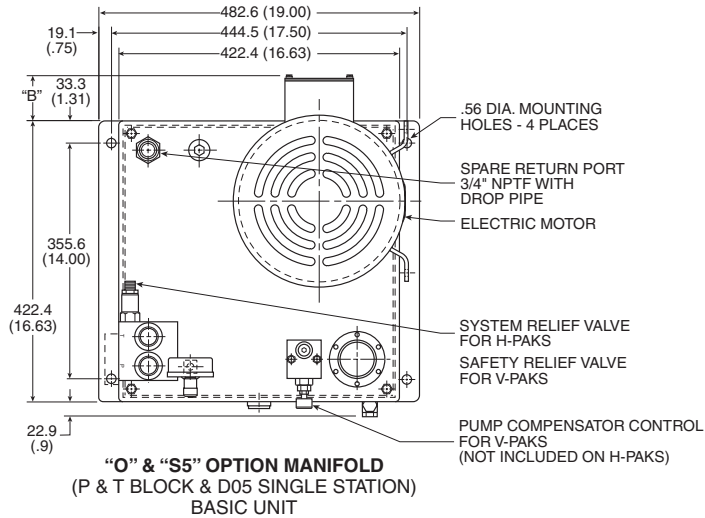

Motor Code	Motor Description KW(HP)-RPM-Frame-Phase	Dimension	
		"A" *	"B"
U1	0.37 (.5)-1725-56C-1	266.70 (10.50)	19.05 (0.75)
C1	0.56 (.75)-1725-56C-1	279.40 (11.00)	19.05 (0.75)
T1	0.75 (1)-1725-56C-1	298.45 (11.75)	19.05 (0.75)
T3	0.75 (1)-1725-56C-3	266.70 (10.50)	19.05 (0.75)
F	1.1 (1.5)-1725-56C-3	273.05 (10.75)	19.05 (0.75)
DG	2 (1.5)-1725 - 56C-3 DUAL RATED	359 (14.1)	19.05 (.75)
DK	3 (2.2) - 1725-182TC DUAL RATED	435 (17.1)	19.05 (.75)
L	3.7 (5)-1725-184TC-3	365.25 (14.38)	28.70 (1.13)
M	5.6 (7.5)-1725-213TC-3	406.40 (16.00)	66.80 (2.63)
N	7.5 (10)-1725-215TC-3	413.51 (16.28)	66.80 (2.63)

* Reference dimension consult factory if critical to application.

Filter Option Reference

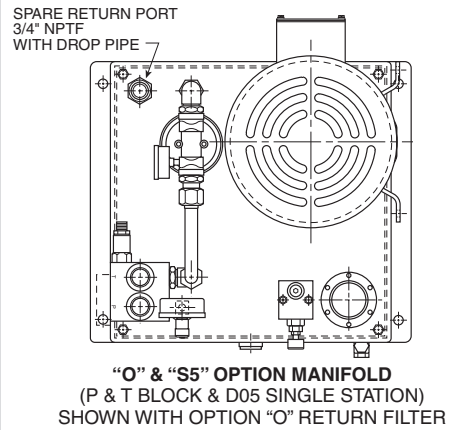

**"O" & "S5" OPTION MANIFOLD
 (P & T BLOCK & D05 SINGLE STATION)
 SHOWN WITH OPTION "O" RETURN FILTER**

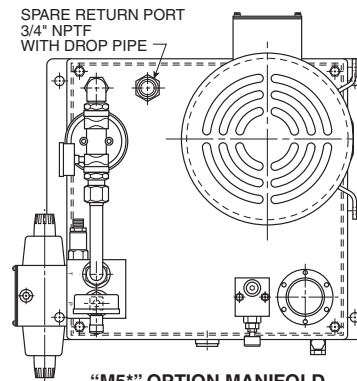
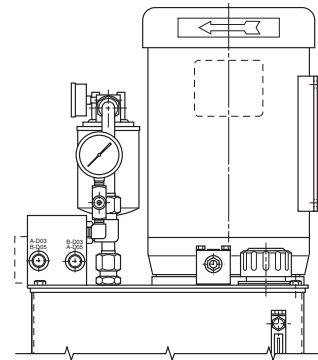

**"M5" OPTION MANIFOLD
 (MULTI-STATION D05 MANIFOLD)
 SHOWN WITH OPTION "O" RETURN FILTER**

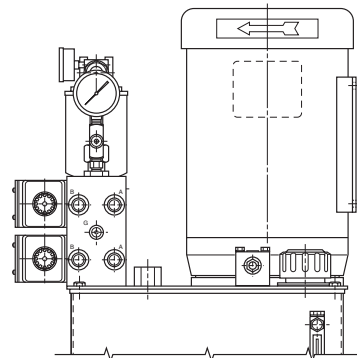

**Dimensions – Basic H2, 3, 4 & V2, 3, 4
 (20, 30, 40 Gallon Tank)**

Inch equivalents for millimeter dimensions are shown in (**).

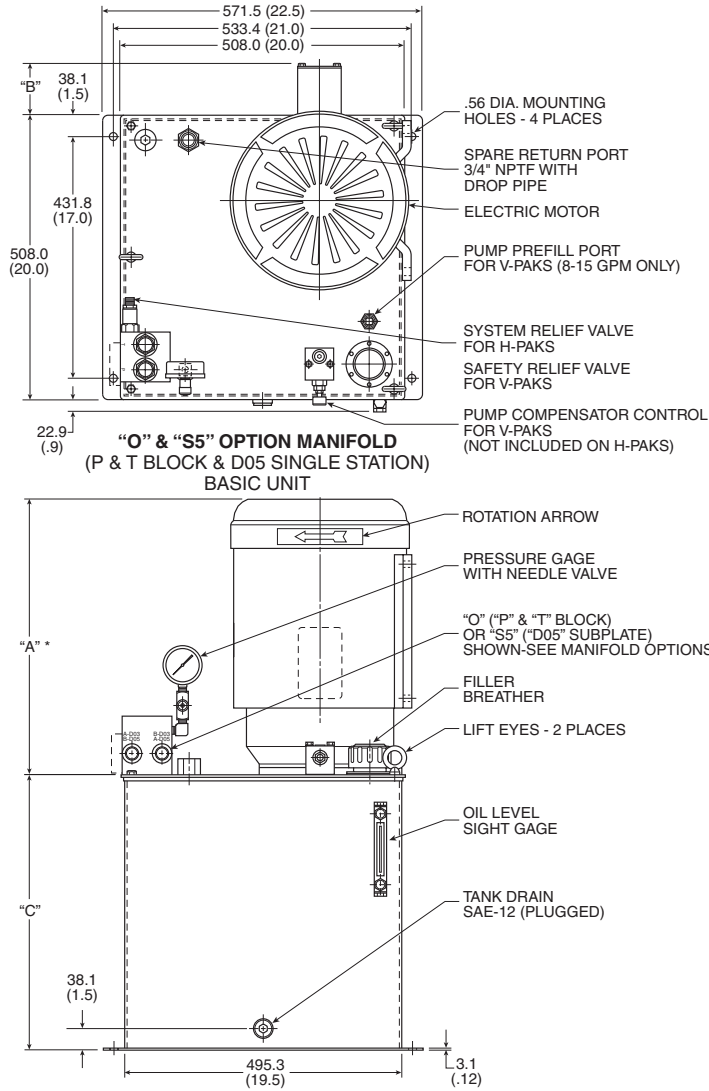

Filter Option Reference

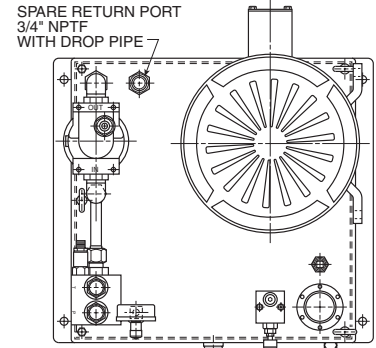

**“O” & “S5” OPTION MANIFOLD
 (P & T BLOCK & D05 SINGLE STATION)
 SHOWN WITH OPTION “N” RETURN FILTER**

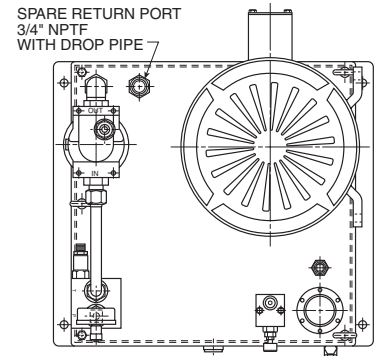
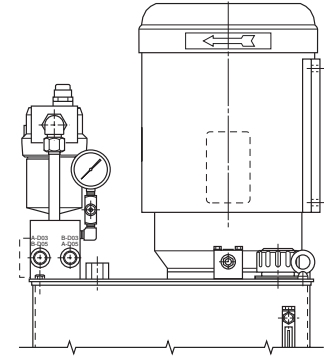

**“M5” OPTION MANIFOLD
 (MULTI-STATION D05 MANIFOLD)
 SHOWN WITH OPTION “N” RETURN FILTER**

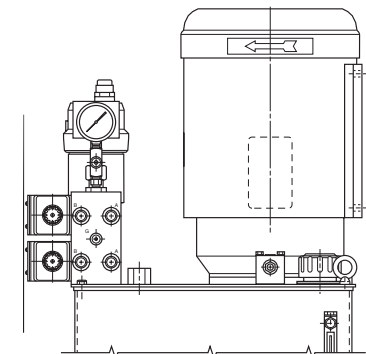

Motor Code	Motor Description KW(HP)-RPM-Frame-Phase	Dimension	
		“A”**	“B”
U1	.37(.5) -1725-56C-1	266.70 (10.50)	19.05 (.75)
C1	.56(.75) -1725-56C-1	279.40 (11.00)	19.05 (.75)
T1	.75(1) -1725-56C-1	298.45 (11.75)	.75 (19.05)
T3	.75(1) -1725-56C-3	266.70 (10.50)	19.05 (.75)
DG	2 (1.5)-1725 - 56C-3 DUAL RATED	359 (14.1)	19.05 (.75)
DK	3 (2.2) - 1725-182TC DUAL RATED	435 (17.1)	19.05 (.75)
L	5 (3.75) - 1725 - 184TC - 3	435 (17.1)	28.70 (1.13)
M	7.5 (5.6) - 1725 - 213TC - 3	458 (18)	35.05 (1.38)
N	10 (7.5) - 1725 - 215TC - 3	473 (18.6)	35.05 (1.38)
P	15 (11.2) - 1725 - 254TC - 3	522 (20.5)	85.09 (3.35)
S	20 (14.9) - 1725 - 256TC - 3 DUAL RATED	522 (20.5)	85.09 (3.35)

Reservoir Code	Reservoir Code	Dimension “C”
H2 or V2	151.4 Liters (20 Gal)	491.74 (19.36)
H3 or V3	113.6 Liters (30 Gal)	599.95 (23.62)
H4 or V4	75.7 Liters (40 Gal)	733.04 (28.86)

Manifold Options

Inch equivalents for millimeter dimensions are shown in (**).

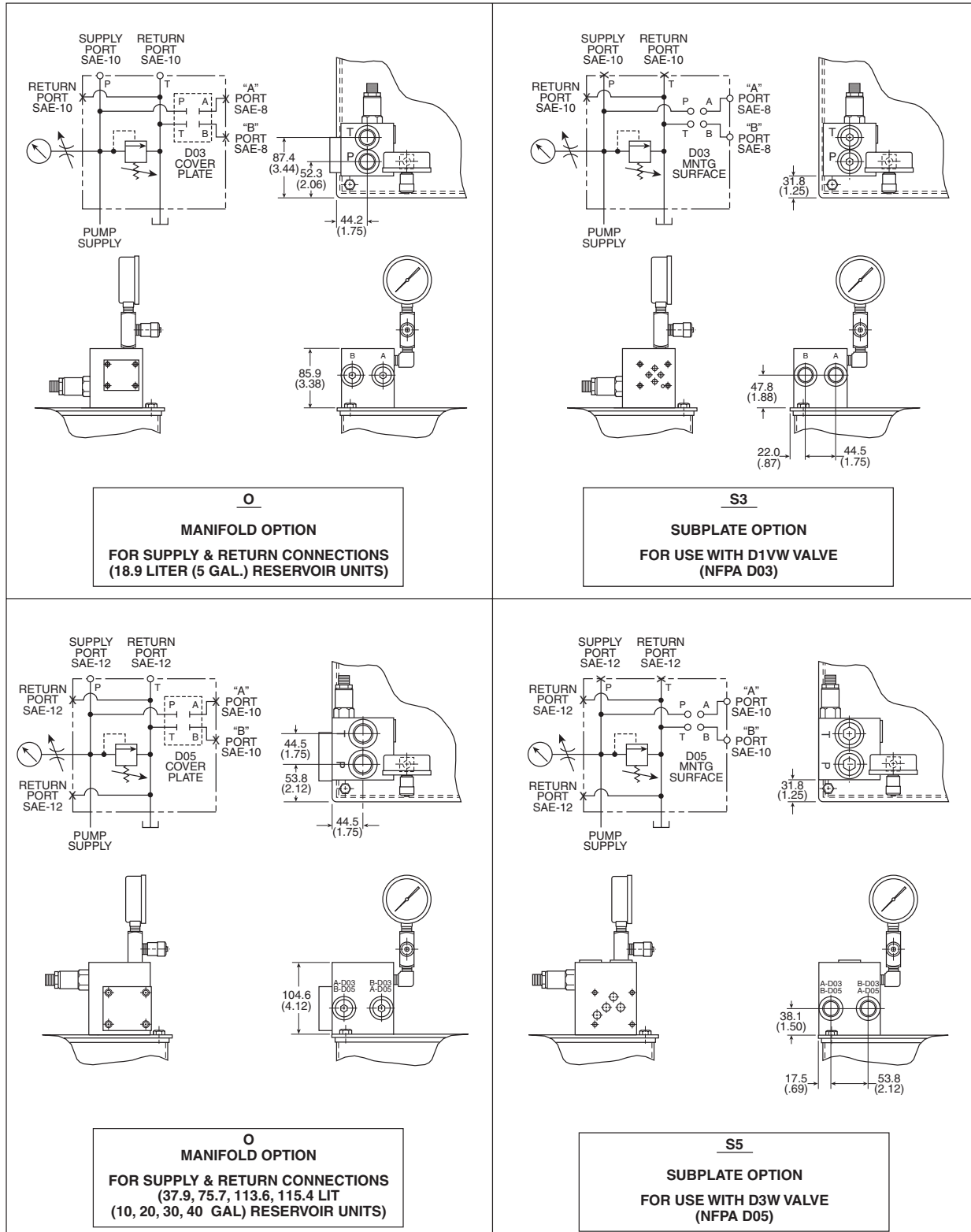

Manifold Options

Inch equivalents for millimeter dimensions are shown in (**).

Option M33/M35

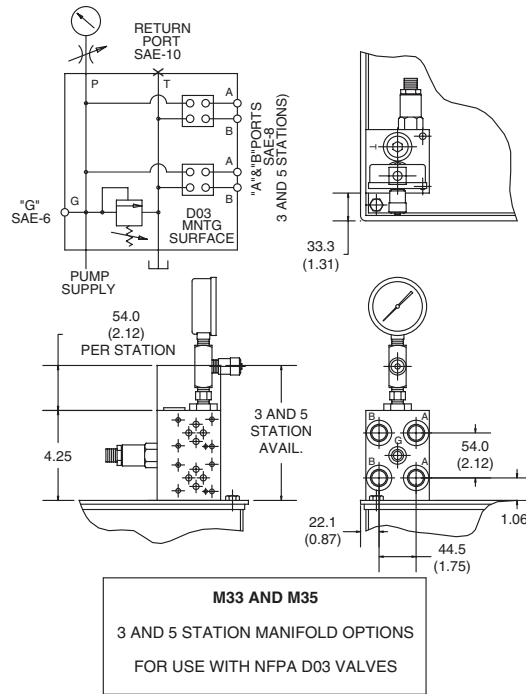

Option M53/M55

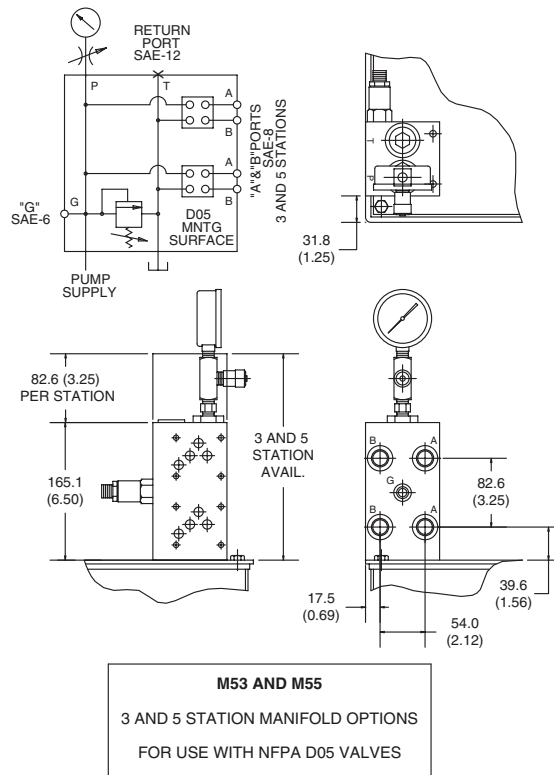

Pressure Control Option "B" – Unloading Valve

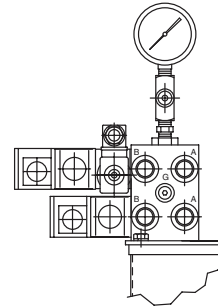
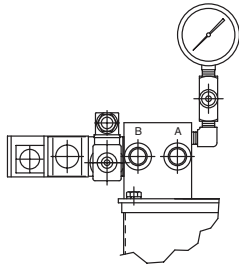
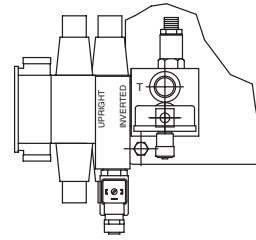
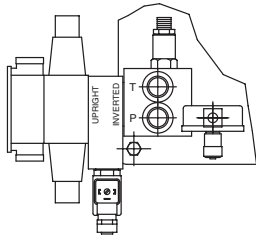

"H"PAK WITH
 "S3" MANIFOLD
 3.4-19.3 LPM (0.9-5.1 GPM) FLOW RATES ONLY
 (CONNECTED TO SYSTEM RETURN LINE)

"H"PAK WITH
 "M3" MANIFOLD
 3.4-19.3 LPM (0.9-5.1 GPM) FLOW RATES ONLY
 (CONNECTED TO SYSTEM RETURN LINE)

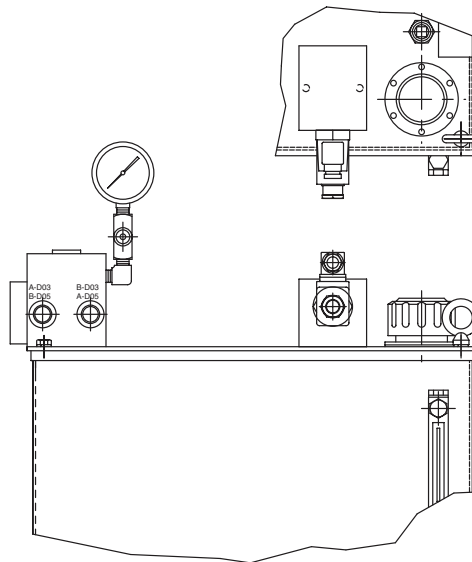
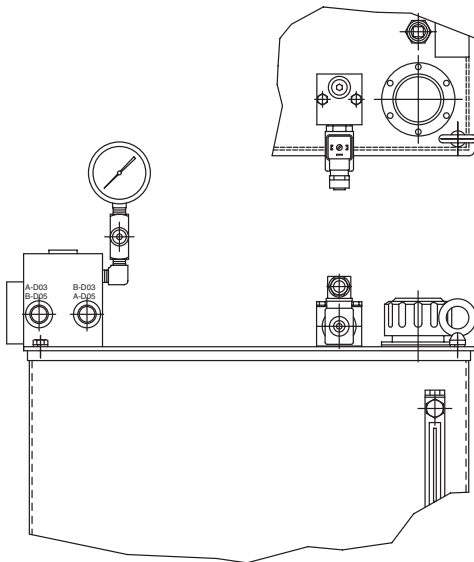

"H"PAK WITH
 "OMIT", "S5", "S6", "M5", "M6" MANIFOLDS
 3.4-19.3 LPM (0.9-5.1 GPM) FLOW RATES ONLY
 (PLUMBED DIRECTLY BACK TO TANK)

"H"PAK WITH
 "OMIT", "S3", "S5", "S6", "M3", "M5", "M6" MANIFOLDS
 23.84-46.56 LPM (6.3-12.3 GPM) FLOW RATES ONLY
 (PLUMBED DIRECTLY BACK TO TANK)

Pressure Control Option "B" – Unloading Valve

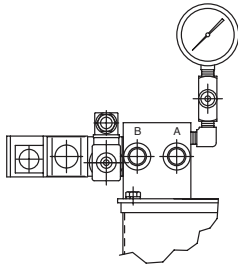
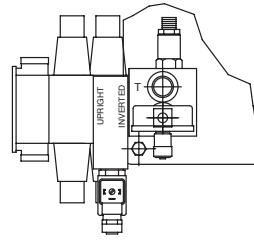
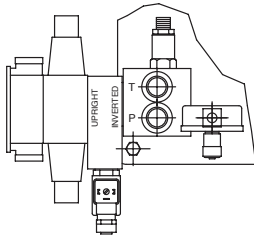

"D"PAK WITH
 "S3" MANIFOLD
 (CONNECTED TO SYSTEM RETURN)

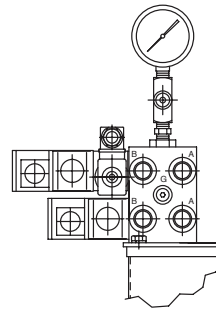

"D"PAK WITH
 "M3" MANIFOLD
 (CONNECTED TO SYSTEM RETURN)

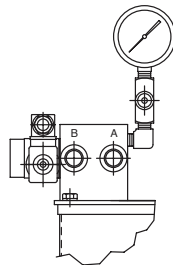
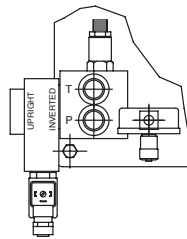

"D"PAK WITH
 "OMIT" MANIFOLD
 (CONNECTED TO SYSTEM RETURN)

V-Pak – Compensator Options

**“OMIT” OPTION
 SINGLE PRESSURE
 REMOTE COMPENSATOR**

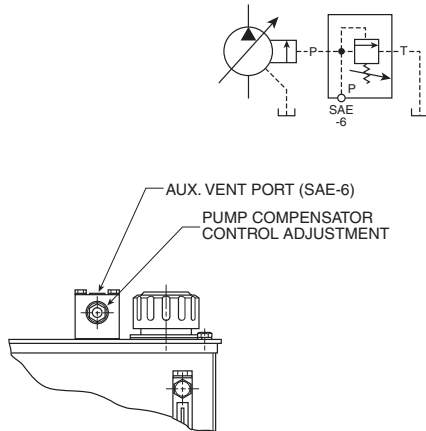

**“B” OPTION
 SINGLE PRESSURE
 REMOTE COMPENSATOR
 W/LOW PRESS. STANDBY**

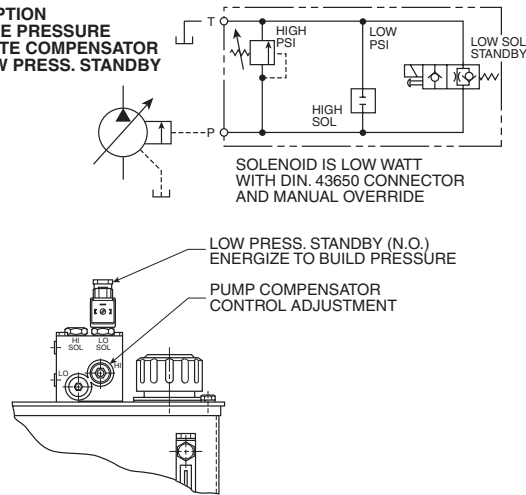

**“C” OPTION
 BI-PRESSURE
 REMOTE COMPENSATOR**

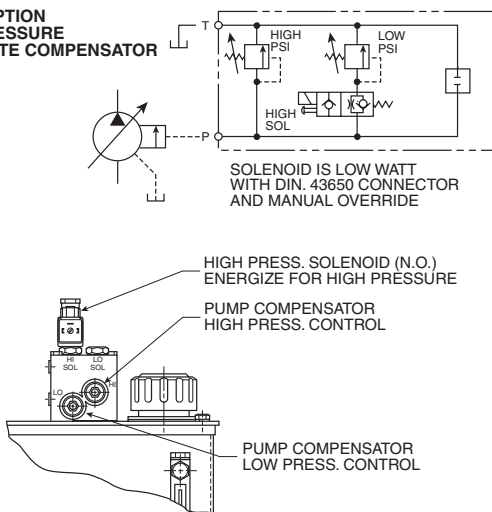

**“D” OPTION
 BI-PRESSURE
 REMOTE COMPENSATOR
 W/LOW PRESS. STANDBY**

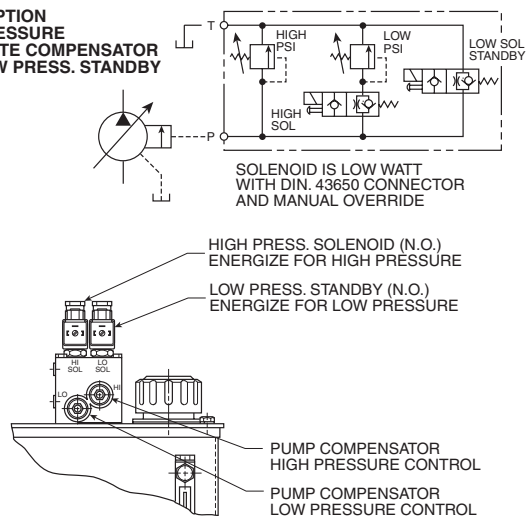

**“F” OPTION
 PROVISION FOR
 CUSTOMER SUPPLIED
 REMOTE COMPENSATOR**

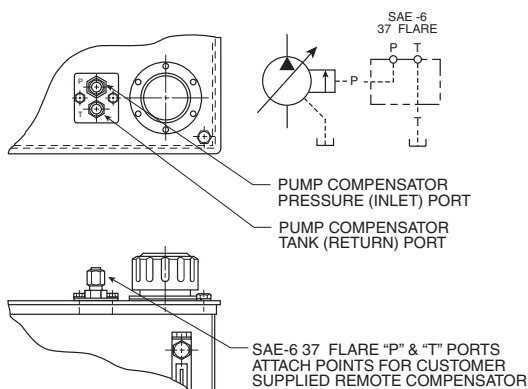

ACCESSORY OPTIONS—D&H PAKS

- | | |
|--|---|
| OPTION (B) RETURN LINE AIR/OIL HEAT EXCHANGER (B1 OR B2) | OPTION (L) CHECK VALVE—RETURN LINE BYPASS |
| OPTION (C) WATER/OIL HEAT EXCHANGER | OPTION (N) RETURN LINE FILTER |
| OPTION (E) SYSTEM COOLING/FILTER LOOP | OPTION (O) RETURN LINE FILTER |
| OPTION (H) PRESSURE FILTER | OPTION (R) COMBINATION TEMP/LEVEL SWITCH (R1 OR R2) |
| OPTION (J) WELD COUPLING FOR HEATER | |
| OPTION (K) CHECK VALVE—PUMP OUTLET | |

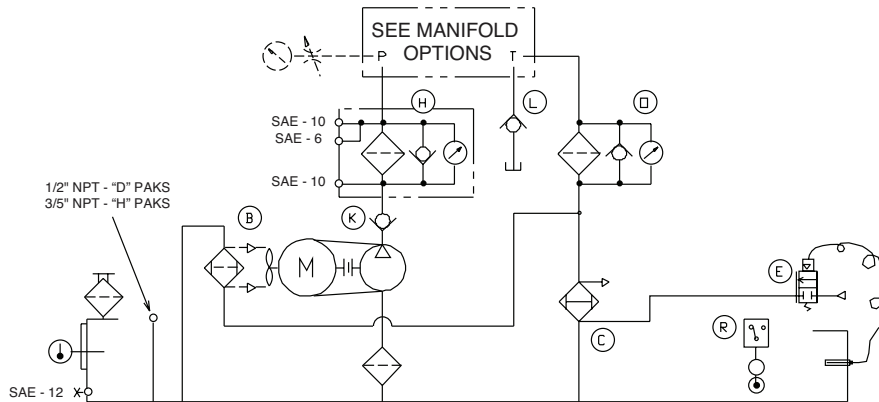

ACCESSORY OPTIONS—V PAKS

- | | |
|--|---|
| OPTION (A) PUMP CASE HEAT EXCHANGER | OPTION (K) CHECK VALVE—PUMP OUTLET |
| OPTION (B) RETURN LINE AIR/OIL HEAT EXCHANGER (B1 OR B2) | OPTION (L) CHECK VALVE—RETURN LINE BYPASS |
| OPTION (C) WATER/OIL HEAT EXCHANGER | OPTION (N) RETURN LINE FILTER |
| OPTION (D) WATER/OIL HEAT EXCHANGER | OPTION (O) RETURN LINE FILTER |
| OPTION (E) WATER CONTROL VALVE | OPTION (R) COMB. TEMP/LEVEL SWITCH (R1 OR R2) |
| OPTION (H) PRESSURE FILTER | |
| OPTION (J) WELD COUPLING FOR HEATER | |

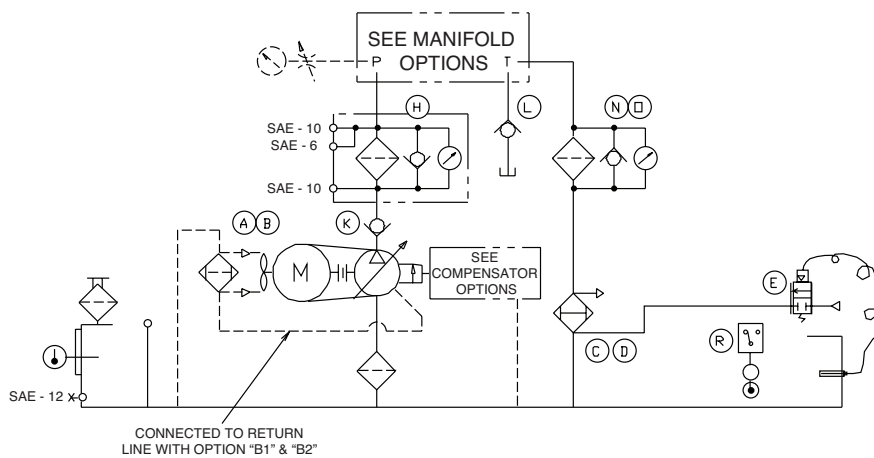

Dimensions – D-Pak (5 Gallon Tank) Accessories

Inch equivalents for millimeter dimensions are shown in (**). Installation information is for reference only. Consult factory or visit Parker's Econfigurator for detailed information.

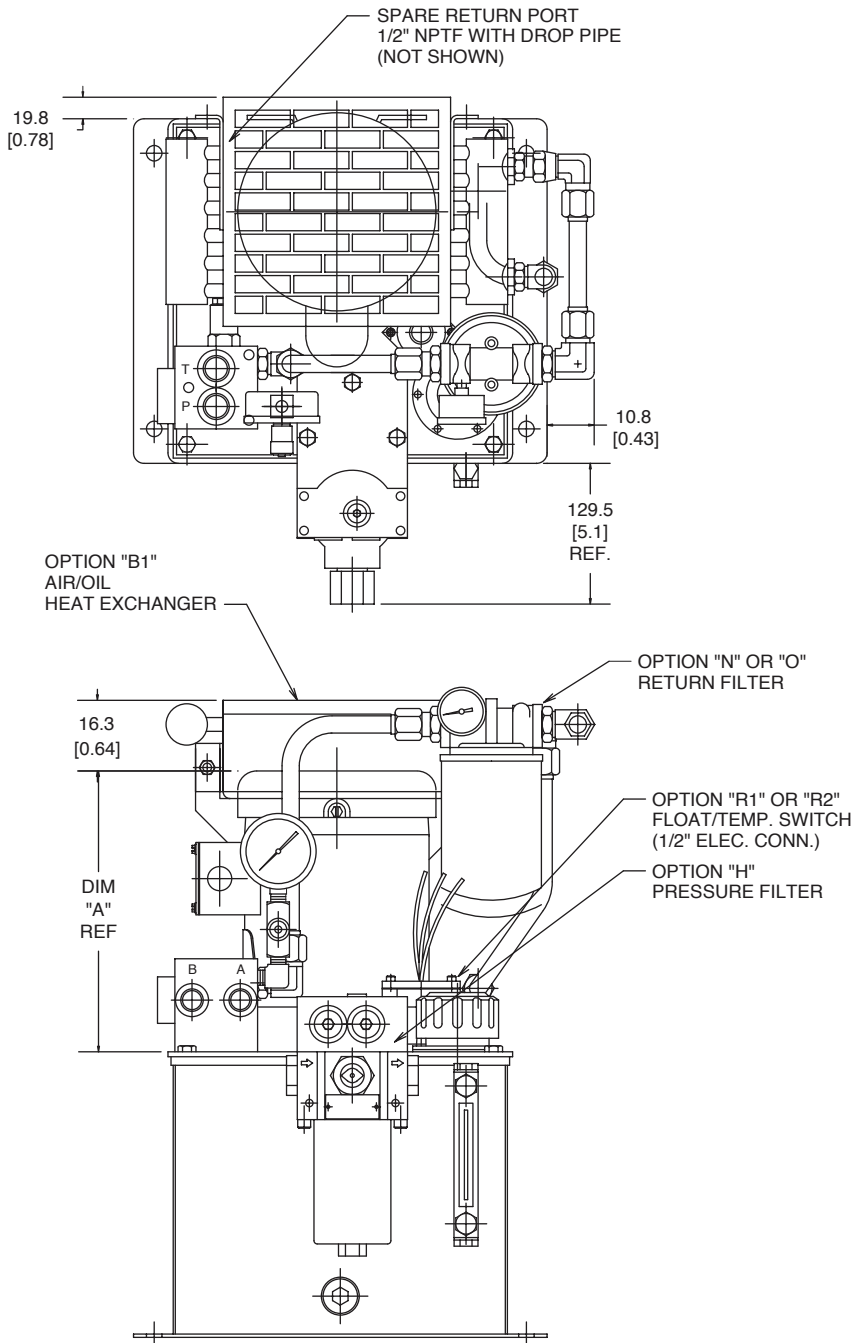

Dimensions – H1 & V1 (10 Gallon Tank) Accessories

Inch equivalents for millimeter dimensions are shown in (**). Installation information is for reference only, consult factory or visit Parker's Econfigurator for detailed information.

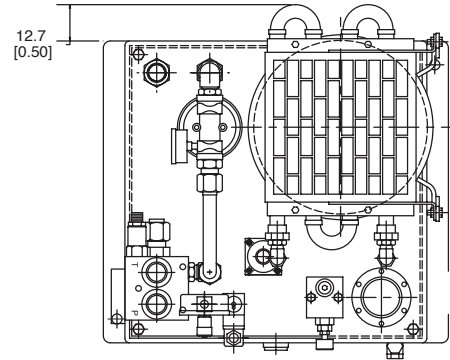
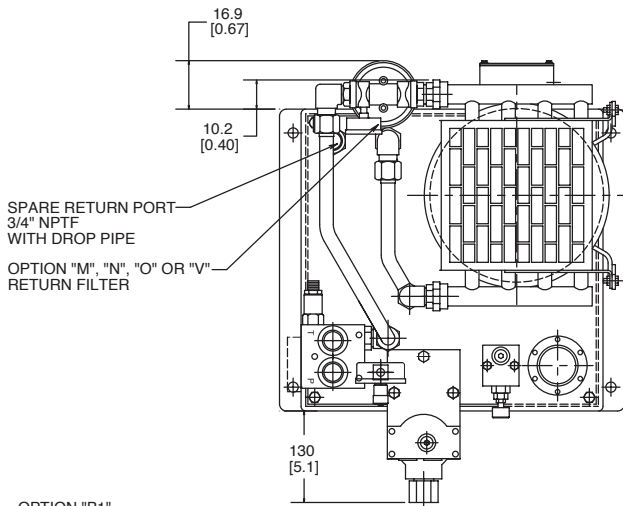

OPTION "B1"
 AIR/OIL
 HEAT EXCHANGER

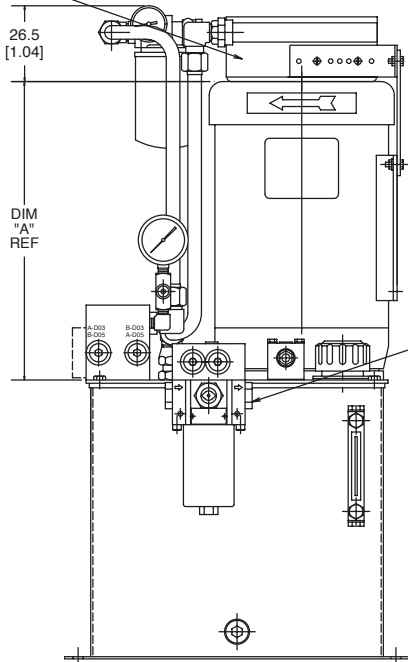

OPTION "A"
 PUMP CASE HEAT EXCHANGER
 (USED ON "V" PA S ONLY)

OPTION "R1" OR "R2"
 FLOAT/TEMP. SWITCH
 (1/2" ELEC. CONN.)

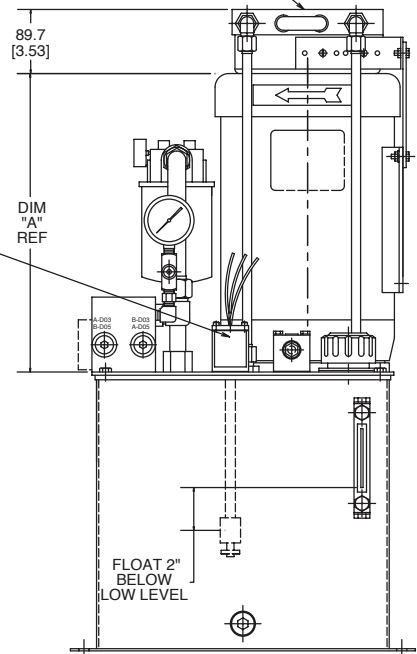

Dimensions – H1 & V1 (10 Gallon tank) Accessories (continued)

NOTE: USE FOR REFERENCE ONLY
 EXACT DIMENSIONS MAY VARY DEPENDING
 ON COMBINATION OF OTHER OPTIONS

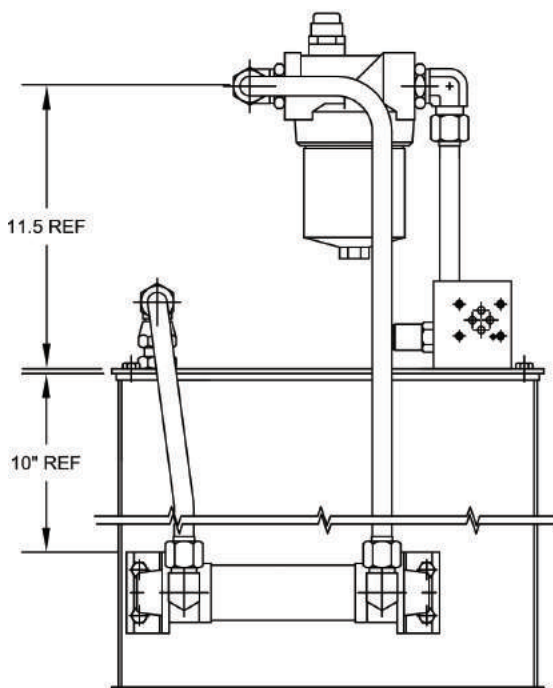
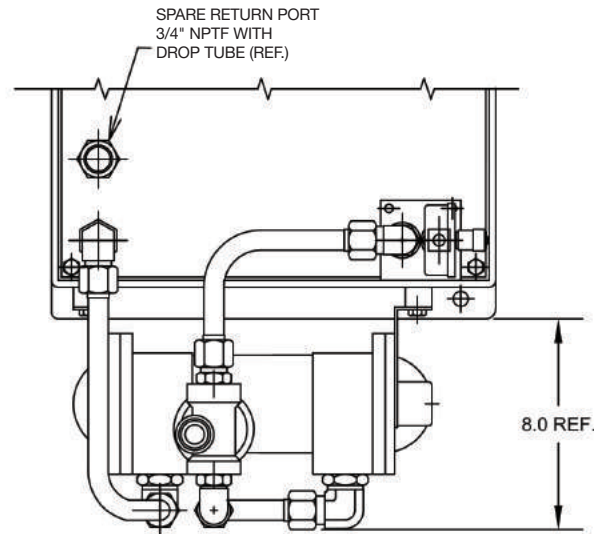
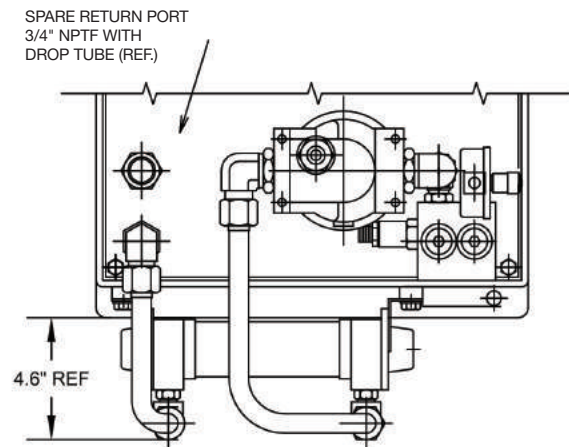

H1 /V1 WITH S3 MANIFOLD
 OPTION "C" WATER/OIL HEAT EXCHANGER
 OPTION "N" 40 CN RETURN FILTER

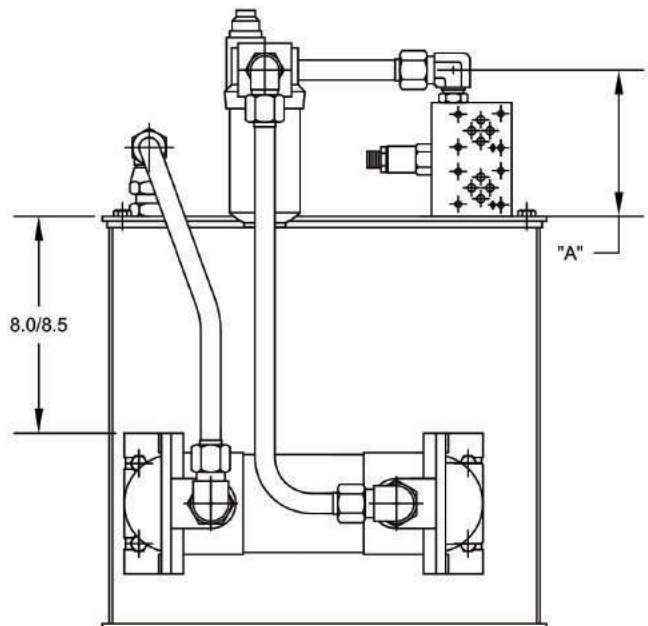

MANIFOLD	DIMENSION "A"
M33	7.6 REF.
M35	11.8 REF.

H1 /V1 WITH M3* MANIFOLD
 OPTION "D" WATER/OIL HEAT EXCHANGER
 OPTION "M" 15 CN / OPTION "O" 12AT RETURN FILTER
 (M32 W /15CN SHOWN)

Dimensions – H1 & V1 (10 Gallon tank) Accessories (continued)

OPTION "E" WATER MODULATING VALVE WITH "C" HEAT EXCHANGER & 10 GALLON TANK

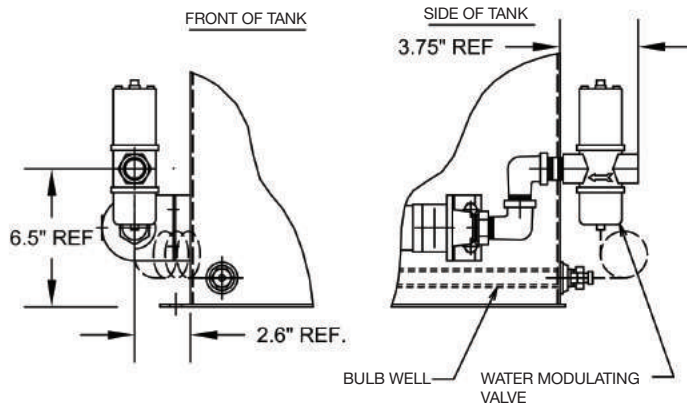

IF OPTION "E" ORDERED WITH NO HEAT EXCHANGER
 THE UNIT WILL BE SUPPLIED
 WITH 3/4" WELD COUPLING ONLY.

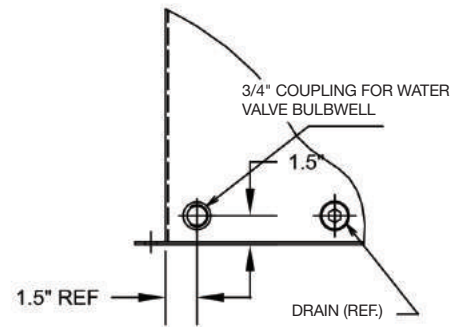

OPTION "E" WATER MODULATING VALVE WITH "D" HEAT EXCHANGER & 10 GALLON TANK

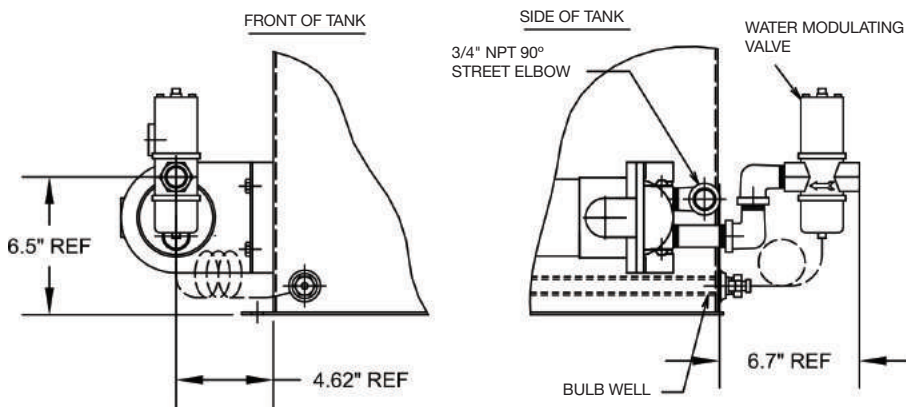

Dimensions – H2, 3, 4 & V2, 3, 4 (20, 30,40 Gallon Tank) Accessories

Inch equivalents for millimeter dimensions are shown in (**). Installation information is for reference only. Consult factory or visit Parker's Econfigurator for detailed information.

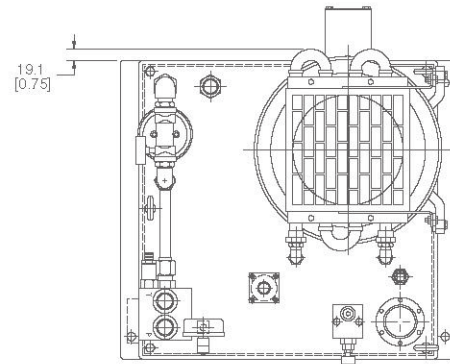
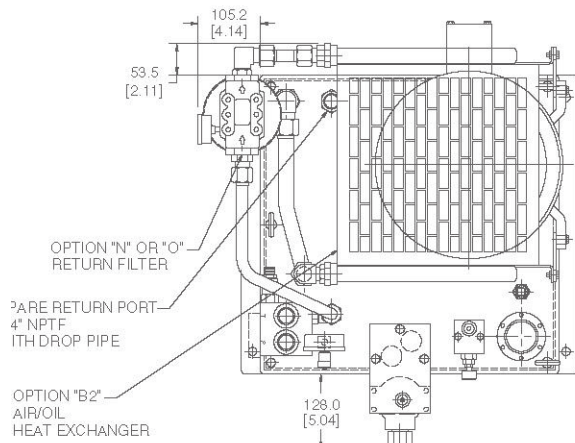

OPTION "A"
 PUMP CASE HEAT EXCHANGER
 (USED ON V-PAKS ONLY)

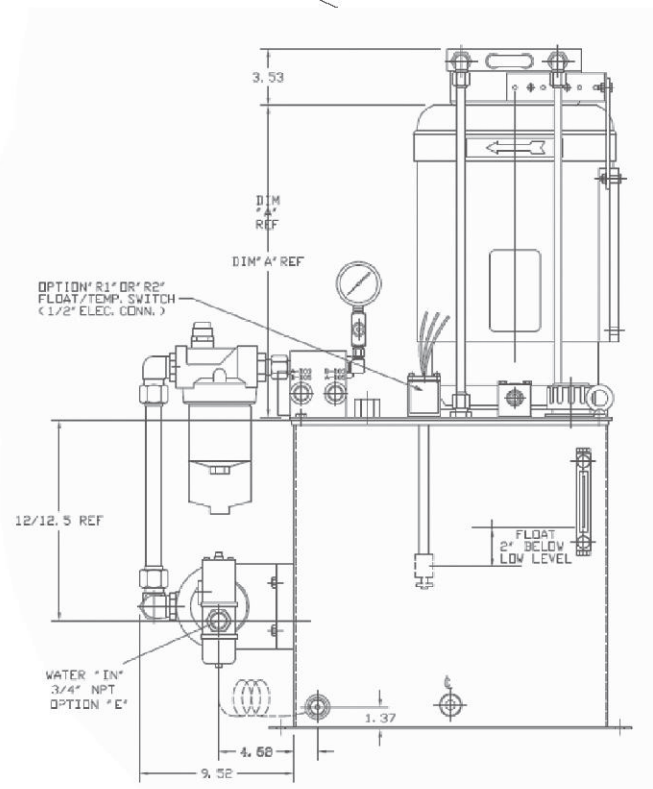
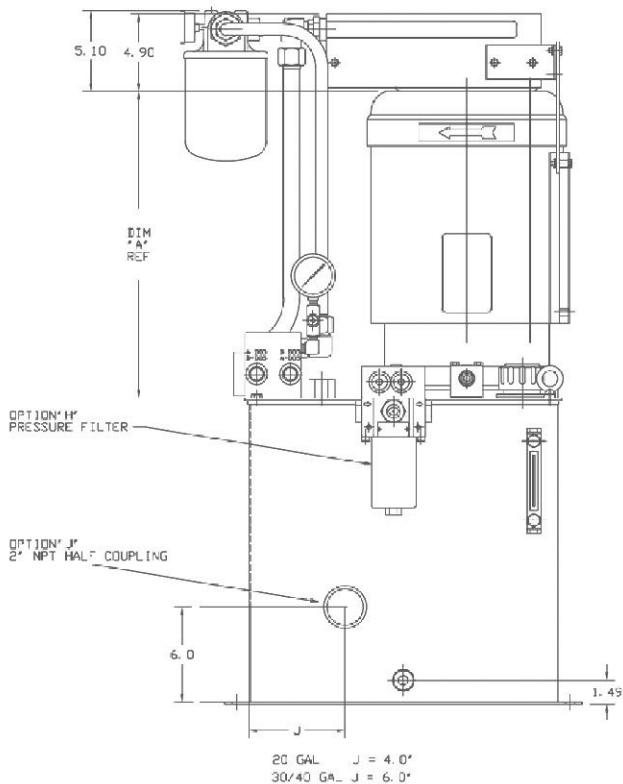

Dimensions – H2, 3, 4 & V2, 3, 4 (20, 30, 40 Gallon Tank) Accessories (CONT)

Inch equivalents for millimeter dimensions are shown in (**). Installation information is for reference only. Consult factory or visit Parker's Econfigurator for detailed information.

NOTE USE FDR REFERENCE ONLY.
 EXACT DIMENSIONS MAY VARY DEPENDING
 ON COMBINATION OF OTHER OPTIONS.

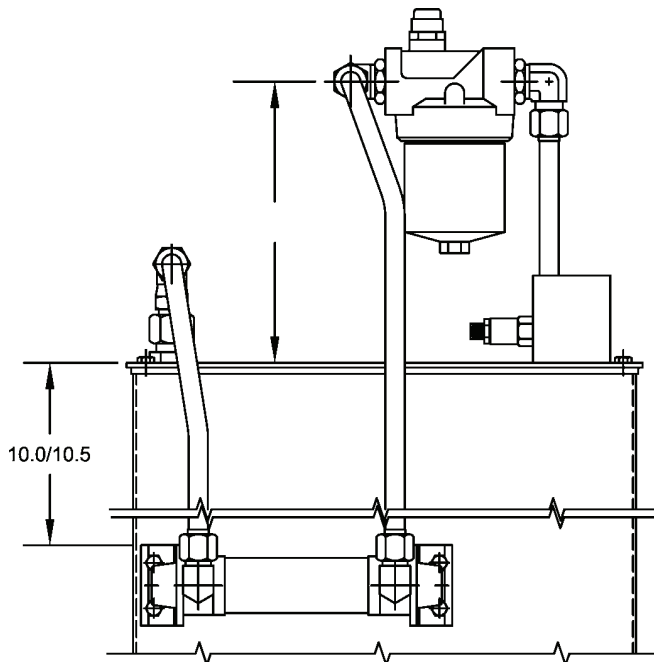
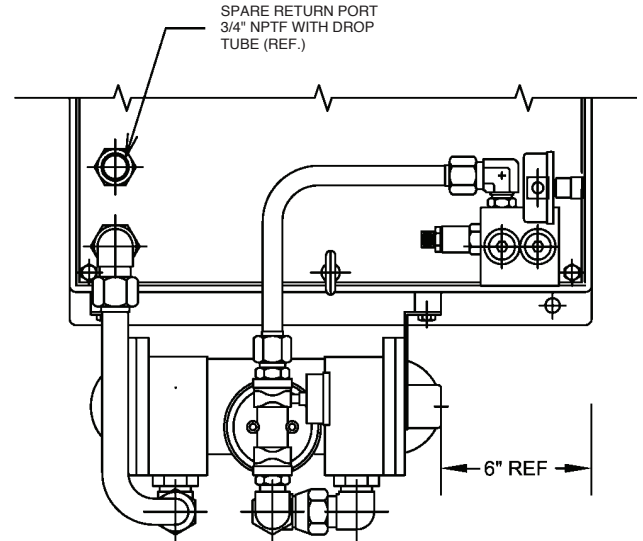
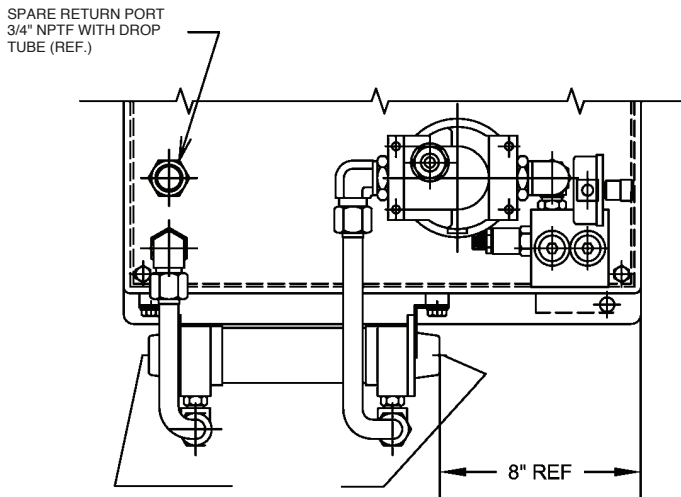

H / V 2,3,4 WITH S3 MANIFOLD
 OPTION "C" WATER/OIL HEAT EXCHANGER
 OPTION "N" 40CN RETURN FILTER

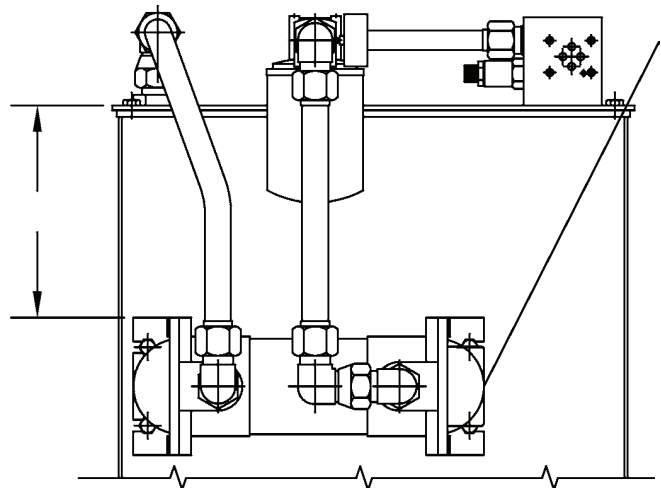

H / V 2,3,4 WITH S3 MANIFOLD
 OPTION "D" WATER/OIL HEAT EXCHANGER
 OPTION "O" 12AT / OPTION "M" 15CN FILTER
 (12AT FILTER SHOWN)

Dimensions – H2, 3, 4 & V2, 3, 4 Accessories (CONT)

Inch equivalents for millimeter dimensions are shown in (**). Installation information is for reference only. Consult factory or visit Parker's Econfigurator for detailed information.

OPTION "E" WATER MODULATING VALVE WITH "C" HEAT EXCHANGER & 20/30/40 GALLON TANK
 (20 GALLON TANK SHOWN)

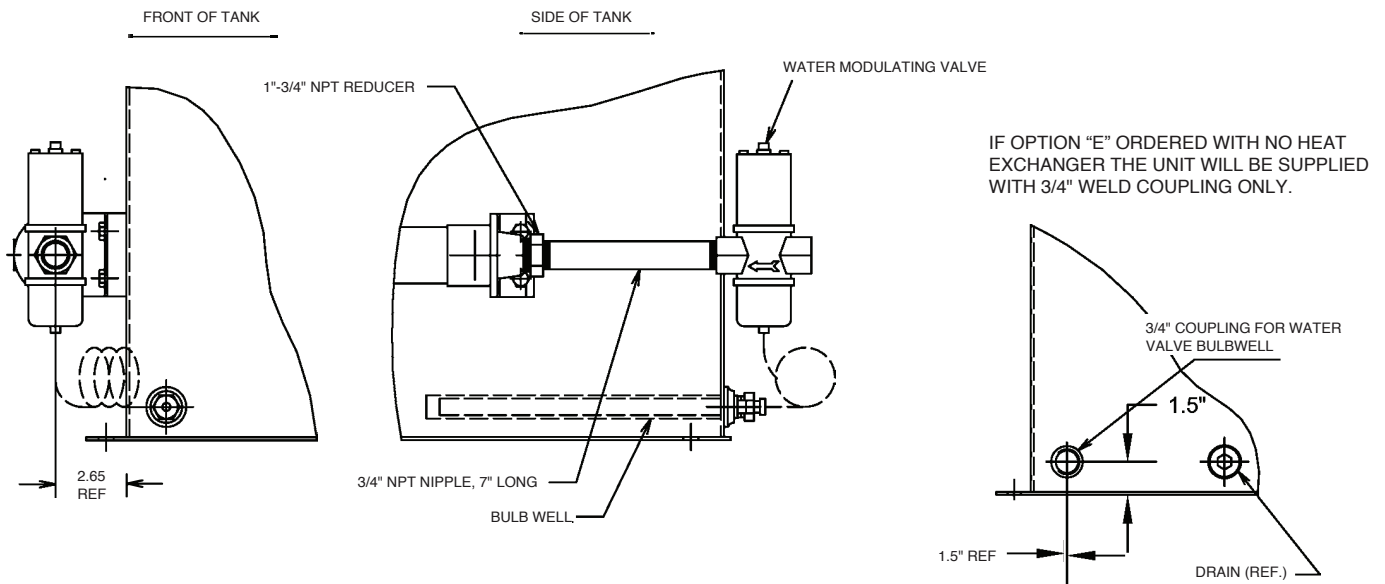

OPTION "E" WATER MODULATING VALVE WITH "D" HEAT EXCHANGER & 20/30/40 GALLON TANK

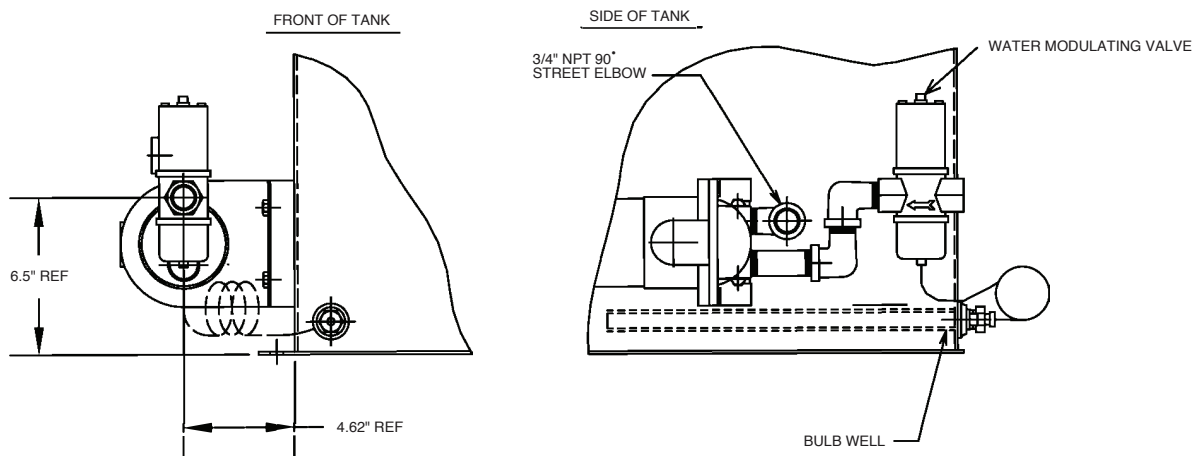

DCP PAK DIMENSIONS

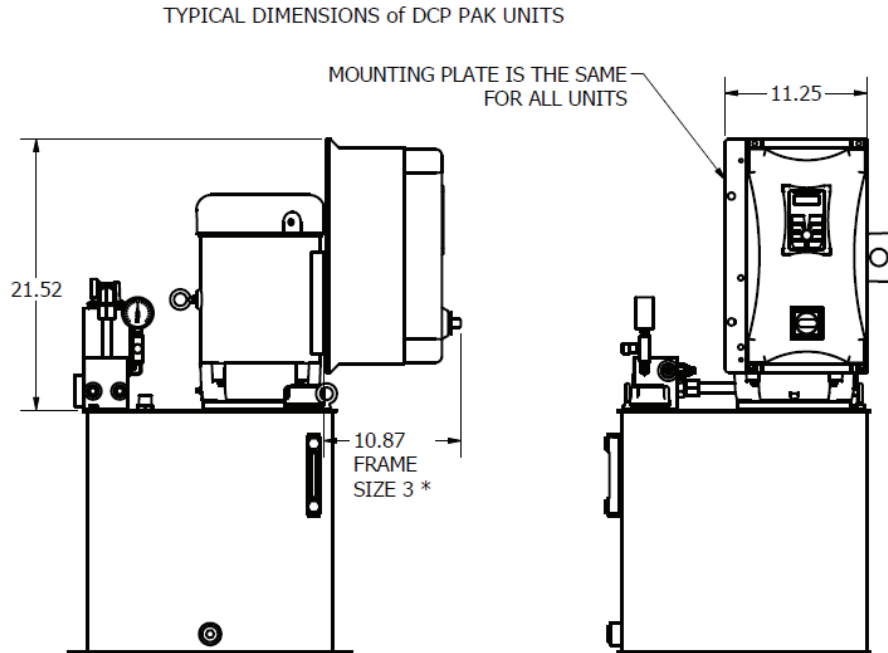

UNITS WILL BE CONFIGURED PER CUSTOMER'S MODEL CODE.
UNITS ARE TESTED PER CONFIGURATION TO ENSURE PROPER OPERATION.

*DIMENSION SHOWN IS DEPTH OF THE AC10 AS MEASURED FROM THE MOTOR FEET. REF H PAK DIMENSIONS EARLIER IN THE CATALOG FOR MORE INFORMATION.

Performance Data – Maximum Working Pressures

- **** Represents maximum operating pressure with pump/motor combination. This will be the maximum relief valve or compensator setting.
- **** Represents maximum operating pressure with pump/motor combination. When used on power unit products, the highest relief valve or compensator setting will be 3000 PSI.

D & H Pak - Pump/Motor Combinations Maximum Operating Pressure Bar (PSI)

Pump Code Flow at 1725 RPM LPM (GPM)	Motor KW (HP)										
	.37 (.5)	.60 (.75)	.75 (1)	1.1 (1.5)	1.5 (2)	2.2 (3)	3.7 (5)	5.6 (7.5)	7.5 (10)	11.2 (15)	14.9 (20)
	Max Operating Pressure (Theoretical)										
3.4 (0.9)	55.8(810)	84.1(1220)	111.7(1620)	167.5(2430)	223.4(3240)						
4.9 (1.3)	40.0(580)	60.0(870)	80.0(1160)	119.3(1730)	159.3(2310)	239.2(3470)					
6.8 (1.8)	29.6(430)	44.1(640)	59.3(860)	88.3(1280)	118.6(1720)	177.2(2570)	275.0(3988)				
8.7 (2.3)	22.8(330)	34.5(500)	46.2(670)	69.0(1000)	92.4(1340)	138.6(2010)	231.0(3350)				
10.2 (2.7)	20.0(290)	30.3(440)	40.0(580)	60.0(870)	80.7(1170)	120.7(1750)	201.3(2920)				
12.1 (3.2)	15.9(230)	24.1(350)	31.7(460)	48.3(700)	64.1(930)	96.5(1400)	160.6(2330)	241.3(3500)			
17.0 (4.5)	11.0(160)	17.2(250)	22.8(330)	33.8(490)	45.5(660)	69.0(1000)	115.1(1670)	172.4(2500)	226.9(3320)		
19.3 (5.1)	10.3(150)	15.2(220)	20.7(300)	30.3(440)	40.7(590)	61.4(890)	102.0(1480)	153.1(2220)	204.1(2960)	275.0(3988)	
23.8 (6.3)	8.3(120)	12.4(180)	16.5(240)	24.8(360)	33.1(480)	49.6(720)	82.7(1200)	124.1(1800)	165.5(2400)	248.2(3600)	
30.7 (8.1)		9.7(140)	12.4(180)	18.6(270)	24.8(360)	37.2(540)	62.7(910)	93.8(1360)	125.5(1820)	187.5(2720)	251.0(3640)
35.6 (9.4)		8.3(120)	11.0(160)	16.5(240)	21.4(310)	32.4(470)	53.8(780)	81.4(1180)	108.2(1570)	162.0(2350)	215.8(3130)
46.6 (12.3)			8.3(120)	11.7(170)	15.9(230)	24.1(350)	40.0(580)	60.0(870)	80.0(1160)	120.0(1740)	160.0(2320)

V-Pak - Pump/Motor Combinations Maximum Operating Pressure Bar (PSI)

Pump	LPM (GPM) @ 1725 RPM	Motor KW (HP)						
		1.5 (2)	2.2 (3)	3.7 (5)	5.6 (7.5)	7.5 (10)	11.2 (15)	14.9 (20)
PVP16	7.6 (2.0)	72.4(1050)	108.2(1570)	179.3(2600)	266.1(3860)			
PVP16	9.5 (2.5)	64.1(930)	94.5(1370)	155.1(2250)	232.4(3370)			
PVP16	11.4 (3.0)	57.2(830)	84.8(1230)	137.9(2000)	206.8(3000)			
PVP16	13.2 (3.5)	51.7(750)	75.8(1100)	124.1(1800)	184.8(2680)	246.1(3570)		
PVP16	15.1 (4.0)	46.9(680)	68.9(1000)	113.8(1650)	168.2(2440)	223.4(3240)		
PVP16	17.0 (4.5)	43.4(630)	63.4(920)	103.4(1500)	153.8(2230)	204.8(2970)	305.4(4430)	
PVP16	18.9 (5.0)	40.0(580)	58.6(850)	96.5(1400)	142.0(2060)	188.9(2740)	281.3(4080)	
PVP16	20.8 (5.5)	37.9(550)	55.2(800)	89.6(1300)	132.4(1920)	175.1(2540)	261.3(3790)	
PVP16	22.7 (6.0)	35.2(510)	51.7(750)	83.4(1210)	123.4(1790)	163.4(2370)	244.1(3540)	
PVP16	24.6 (6.5)	33.1(480)	48.3(700)	77.9(1130)	115.8(1680)	153.0(2220)	228.2(3310)	
PVP16	26.5 (7.0)	31.0(450)	45.5(660)	73.8(1070)	108.9(1580)	144.8(2100)	215.1(3120)	
PVP33	30.3 (8.0)			66.2(960)	97.9(1420)	129.6(1880)	193.1(2800)	255.1(3700)
PVP33	32.2 (8.5)			64.1(930)	93.1(1350)	123.4(1790)	182.7(2650)	242.7(3520)
PVP33	34.1 (9.0)			60.7(880)	88.9(1290)	117.2(1700)	174.4(2530)	231.0(3350)
PVP33	36.0 (9.5)			57.9(840)	84.8(1230)	112.4(1630)	166.2(2410)	220.6(3200)
PVP33	37.9 (10.0)			55.2(800)	81.4(1180)	106.9(1550)	159.3(2310)	206.8(3000)
PVP33	39.7 (10.5)			53.1(770)	77.9(1130)	102.7(1490)	152.4(2210)	202.7(2940)
PVP33	41.6 (11.0)			51.0(740)	75.2(1090)	98.6(1430)	146.9(2130)	194.4(2820)
PVP33	43.5 (11.5)			49.0(710)	72.4(1050)	95.1(1380)	141.3(2050)	186.8(2710)
PVP33	45.4 (12.0)			47.6(690)	69.6(1010)	91.7(1330)	135.8(1970)	180.0(2610)
PVP33	47.3 (12.5)			46.2(670)	66.9(970)	88.3(1280)	131.0(1900)	173.7(2520)
PVP33	49.2 (13.0)			44.8(650)	64.8(940)	85.5(1240)	126.9(1840)	167.5(2430)
PVP33	51.1 (13.5)			43.4(630)	62.7(910)	82.7(1200)	122.7(1780)	162.0(2350)
PVP33	53.0 (14.0)			42.1(610)	60.7(880)	80.0(1160)	118.6(1720)	157.2(2280)
PVP33	54.9 (14.5)			40.7(590)	59.3(860)	77.9(1130)	115.1(1670)	152.4(2210)
PVP33	56.8 (15.0)			39.3(570)	57.2(830)	75.2(1090)	111.7(1620)	147.5(2140)



Performance Data – Pumps

Standard Pumps

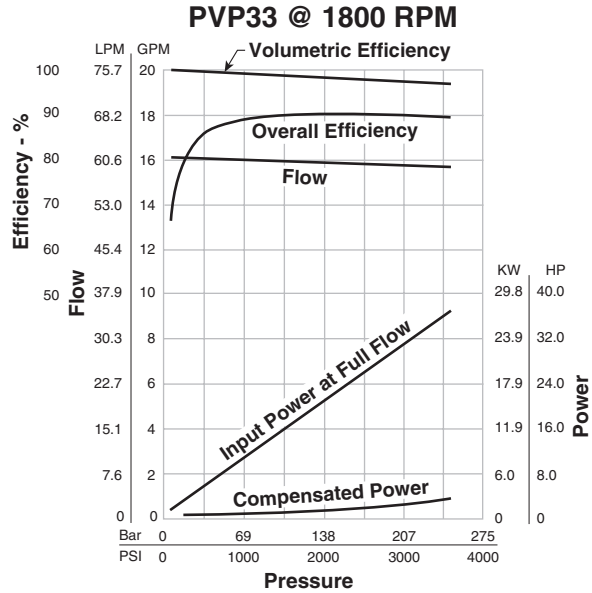
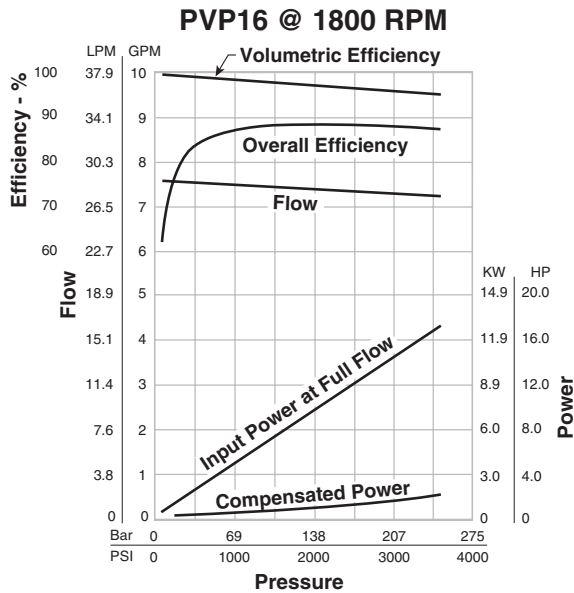

NOTE: The efficiencies and data in the graph are good only for pumps running at 1800 RPM and stroked to maximum. To calculate approximate horsepower for the other conditions, use the following formula:

$$HP = \left[\frac{Q \times (PSI)}{1714} \right] + (CHp) \times \frac{N}{1800}$$

Actual GPM is directly proportional to drive speed and maximum volume setting. Flow loss, however, is a function of pressure only.

WHERE:

- Q = Actual Output Flow in GPM
- PSI = Pressure At Pump Outlet
- CHp = Input Horsepower @ Full compensation @ 1800 RPM (from graph read at operating pressure)
- N = Drive Speed in RPM

Horsepower Limited Pumps

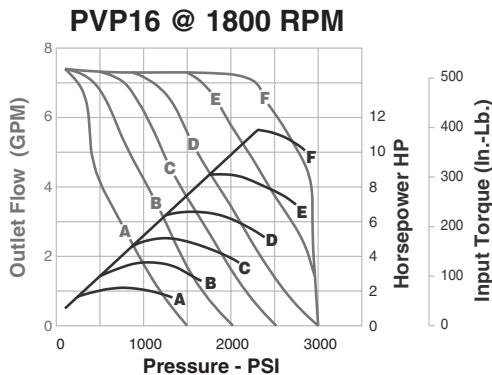

	MOTOR KW (HP)					
	1.5(2)	2.2(3)	3.7(5)	5.6(7.5)	7.5(10)	11.2(15)
	Compensator Setting Bar (PSI)					
PVP16	110.3	151.7	206.8	206.8	206.8	206.8
FULL STROKE	(1600)	(2200)	(3000)	(3000)	(3000)	(3000)

Pump Control Option "H" with PVP16
 Horsepower Limiting
 Factory Compensator Settings

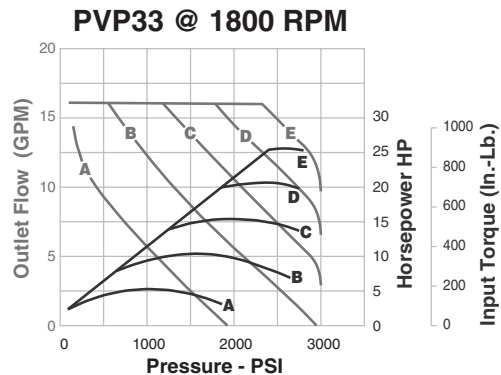

	MOTOR KW (HP)			
	5.6(7.5)	7.5(10)	11.2(15)	14.9(20)
	Compensator Setting Bar (PSI)			
PVP33	151.7	186.2	206.8	206.8
FULL STROKE	(2200)	(2700)	(3000)	(3000)

Pump Control Option "H" with PVP33
 Horsepower Limiting
 Factory Compensator Settings

Performance Data – Heat Exchangers

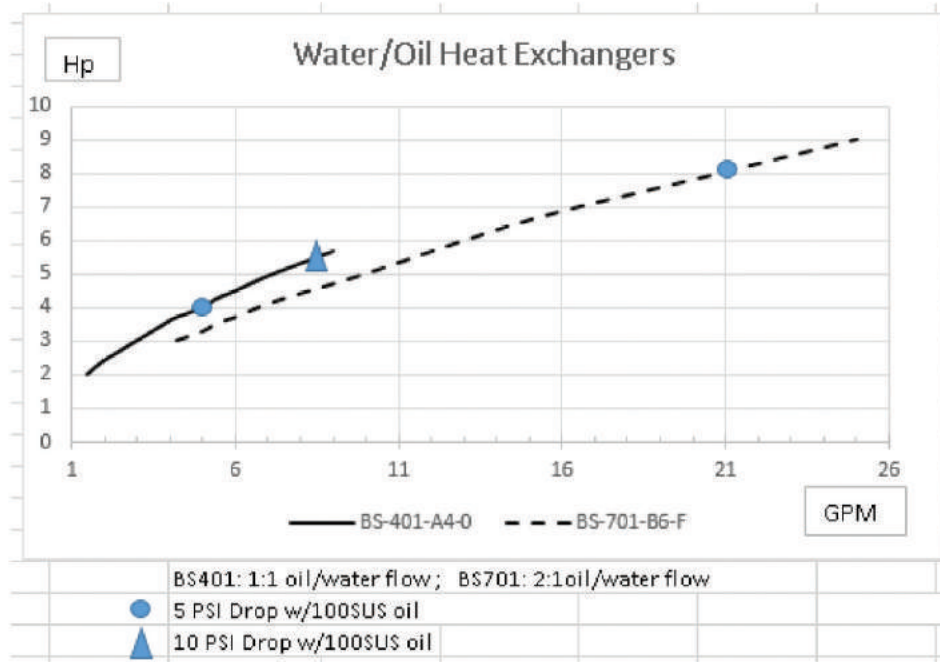
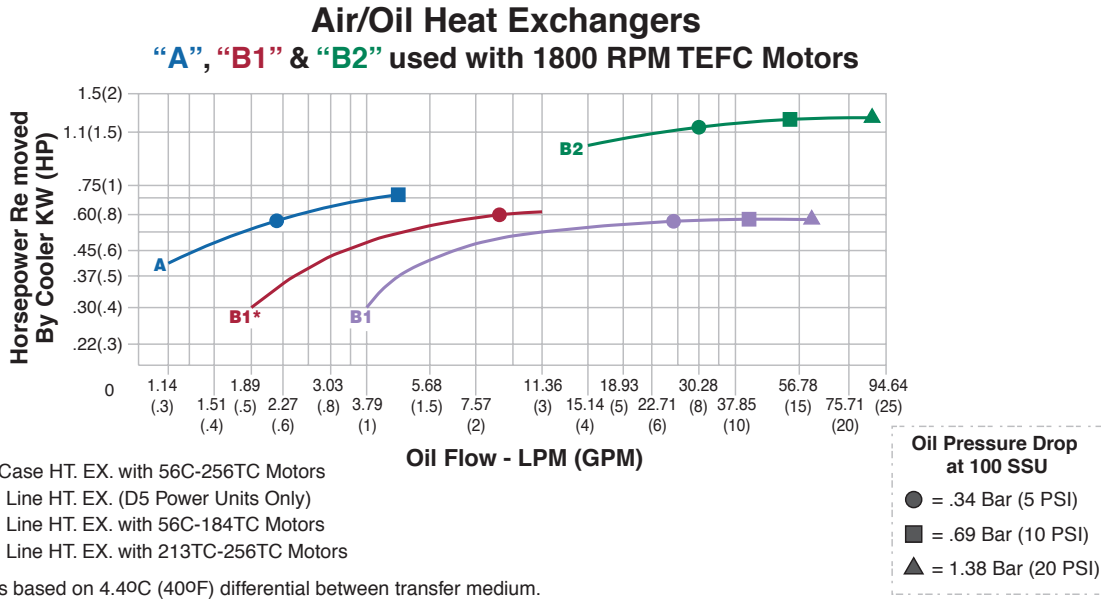

**Horsepower Removed
 By Reservoir**

	RESERVOIR SIZE LITERS (GALLONS)				
	18.9(5)	37.9(10)	75.7(20)	113.6(30)	151.4(40)
KW (HP) REMOVAL	.15(.2)	.28(.38)	.43(.58)	.51(.68)	.60(.81)

Heat removal is based on static ambient air at 29.40C (850F) and max. oil temperature of 57.20C (1350F).

Introduction

Parker's DCP Pak (Drive Controlled Pak) is our H Pak power unit with SSD's AC10 inverter. The AC10 is mounted, wired, configured and factory tested. Simply connect power per local safety regulations, fill the unit with oil and you're ready to run. The AC10 has a lockable disconnect mounted on the front of the unit and has an IP66 rating.

**Reliability & Energy Savings**

1. Parker's DCP Pak saves energy and improves reliability compared to units that use normal motor starters.
2. If rush current is eliminated, the unit reduces power consumption and wear on the motor and couplings.
3. The unit's operation can be set to match the system demand, resulting in less power consumption.
4. Less heat generation improves component and oil life.
5. Most applications run at least part time below 1800 RPM, resulting in quieter operation.
6. Less running time at max RPM improves component life, especially for the pump and motor.
7. A constant 95% power factor results in more efficient use of the electric motor, especially on larger motors that are only partially loaded and aren't controlled by an inverter.
8. The unit has the ability to start and stop the motor as often as necessary without damaging the motor. This results in less wear and tear on the pump/motor coupling and reduced power consumption due to reduced in-rush current.

Dual Rated CE Motors: While using a dual rated motor is not necessary when using an inverter, customers often request motors with a "CE" certification. If you require a motor with the "CE" mark, select the "D" prefix in the motor horsepower section of the H Pak model code. For example, "DL" will select a dual rated CE marked 5Hp (L) motor.

Sample Power Comparison When Used on a Transfer, Clamp and Transfer Application.

The blue line represents the power consumed using a single speed pump.
 The orange line shows the power consumption using a Parker DCP in 2 speed mode.

Cumulative Power Usage:

C
 C
 C
 C

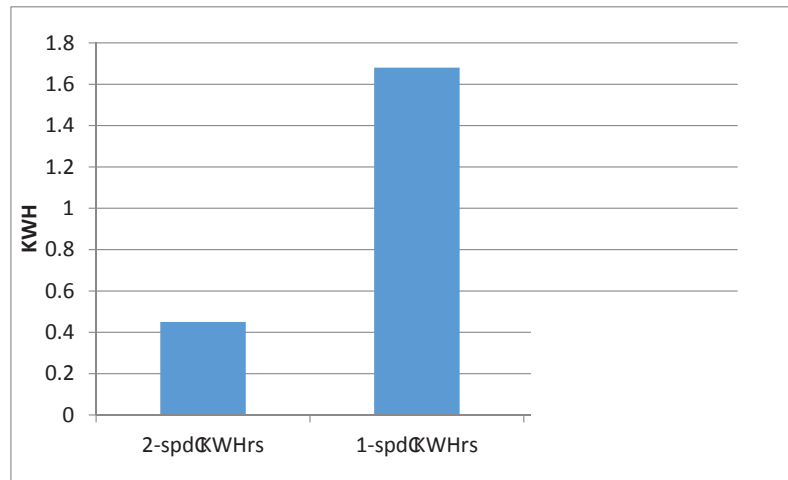
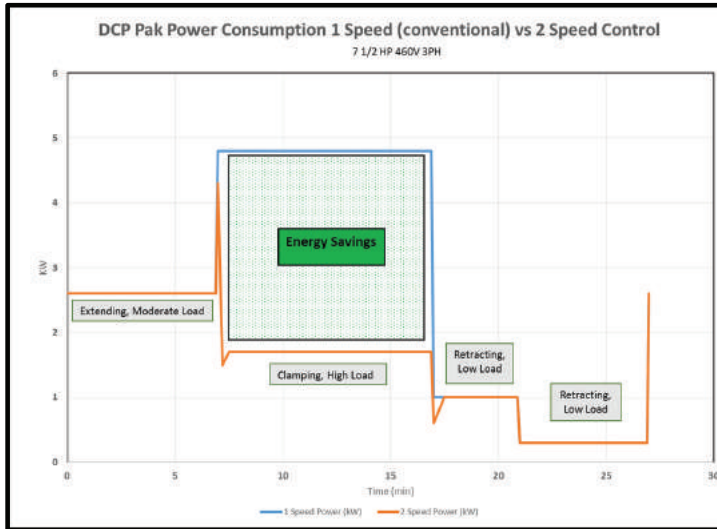

C

C

Available Configurations:

PARKER'S DCP Pak is available in 5 factory set options. The software and settings that are required for the selected option will be downloaded and tested before the unit is shipped. The 5 options are described in the following section. Once the unit is received, it can be installed and used without any programming from the customer. If desired, some variables can be adjusted via the unit's keypad, or additional edits can be performed by using a laptop computer. For detailed information regarding the drive, please refer to the drive's product manual HA502703U001, available at www.parker.com or contact Parker's SSD Division.

It is the customer's responsibility to install this equipment to meet all required safety standards. Proper electrical isolation for maintenance and arc flash control must be provided.

**FAILURE OR IMPROPER SELECTION OR IMPROPER USE OF
THE PRODUCTS DESCRIBED HEREIN OR RELATED ITEMS
CAN CAUSE DEATH, PERSONAL INJURY AND PROPERTY
DAMAGE.**



WARNING: Branch circuit protection with a maximum rating of 5KA current limiting must be supplied per local electrical codes.

Hazards**DANGER! - Ignoring the following may result in injury**

- | | |
|--|---|
| <p>8. This equipment can endanger life by exposure to rotating machinery and high voltages.</p> <p>9. The equipment must be permanently earthed due to the high earth leakage current, and the drive motor must be connected to an appropriate safety earth.</p> <p>10. Ensure all incoming supplies are isolated before working on the equipment. Be aware that there may be more than one supply connection to the drive.</p> <p>11. There may still be dangerous voltages present at power terminals (motor output, supply input phases, DC bus and the brake, where fitted) when the motor is at standstill or is stopped.</p> | <p>12. For measurements use only a meter to IEC 61010 (CAT III or higher). Always begin using the highest range. CAT I and CAT II meters must not be used on this product.</p> <p>13. Allow at least 5 minutes for the drive's capacitors to discharge to safe voltage levels (<50V). Use the specified meter capable of measuring up to 1000V dc & ac rms to confirm that less than 50V is present between all power terminals and earth.</p> <p>14. Unless otherwise stated, this product must NOT be dismantled. In the event of a fault the drive must be returned. Refer to "Routine Maintenance and Repair".</p> |
|--|---|

WARNING! - Ignoring the following may result in injury or damage to equipment**SAFETY**

Where there is conflict between EMC and Safety requirements, personnel safety shall always take precedence.

- | | |
|--|--|
| <ul style="list-style-type: none"> • Never perform high voltage resistance checks on the wiring without first disconnecting the drive from the circuit being tested. • While ensuring ventilation is sufficient, provide guarding and/or additional safety systems to provide injury or damage to equipment. • When replacing a drive in an application and before returning to use, it is essential that all user defined parameters for the product's operation are correctly installed. • The AC10 series is not a safety component or safety related product | <ul style="list-style-type: none"> • All control and signal terminals are SELV, i.e. protected by double insulation. Ensure all external wiring is rated for the highest system voltage. • Thermal sensors contained within the motor must have at least basic insulation. • All exposed metalwork in the Inverter is protected by basic insulation and bonded to a safety earth. • RCDs are not recommended for use with this product but, where their use is mandatory, only Type B RCDs should be used. |
|--|--|

EMC

- | | |
|---|--|
| <ul style="list-style-type: none"> • In a domestic environment this product may cause radio interference in which case supplementary mitigation measures may be required. • This equipment contains electrostatic discharge (ESD) sensitive parts. Observe static control precautions when handling, installing and servicing this product. | <ul style="list-style-type: none"> • This is a product of the restricted sales distribution class according to IEC 61800-3. It is designated as "professional equipment" as defined in EN61000-3-2. Permission of the supply authority shall be obtained before connection to the low voltage supply. |
|---|--|

CAUTION!**APPLICATION RISK**

- The specifications, processes and circuitry described herein are for guidance only and may need to be adapted to the user's specific application. We can not guarantee the suitability of the equipment described in this manual for individual applications.

Control Options

Analog Speed Control: You can provide either a 4-20mA (option I) or 0-10VDC (option V) command signal to control RPM. The unit will be pre-configured based on your model code selection and is scaled to operate between 500 RPM at minimum signal and 2000 RPM at maximum signal. One digital signal (contact closure or 24VDC source) is required to enable the drive and another is required to start and stop the drive. The min and max values can be changed (ref to the AC10 operating manual) but it is not recommended that the minimum setting be set any lower and that the maximum setting not be set any higher. Pump efficiency drops dramatically below 500RPM and pump and or motor damage may result with speeds above 2200RPM.

CAUTION: Disabling the drive DOES NOT remove power from the motor. High voltage can be present at the motor leads even when the motor is not running. To ensure the motor is safe to wire, make sure the disconnect is locked in the OFF position, incoming power is removed and the AC10's display and LED's are off, indicating the capacitors are discharged.

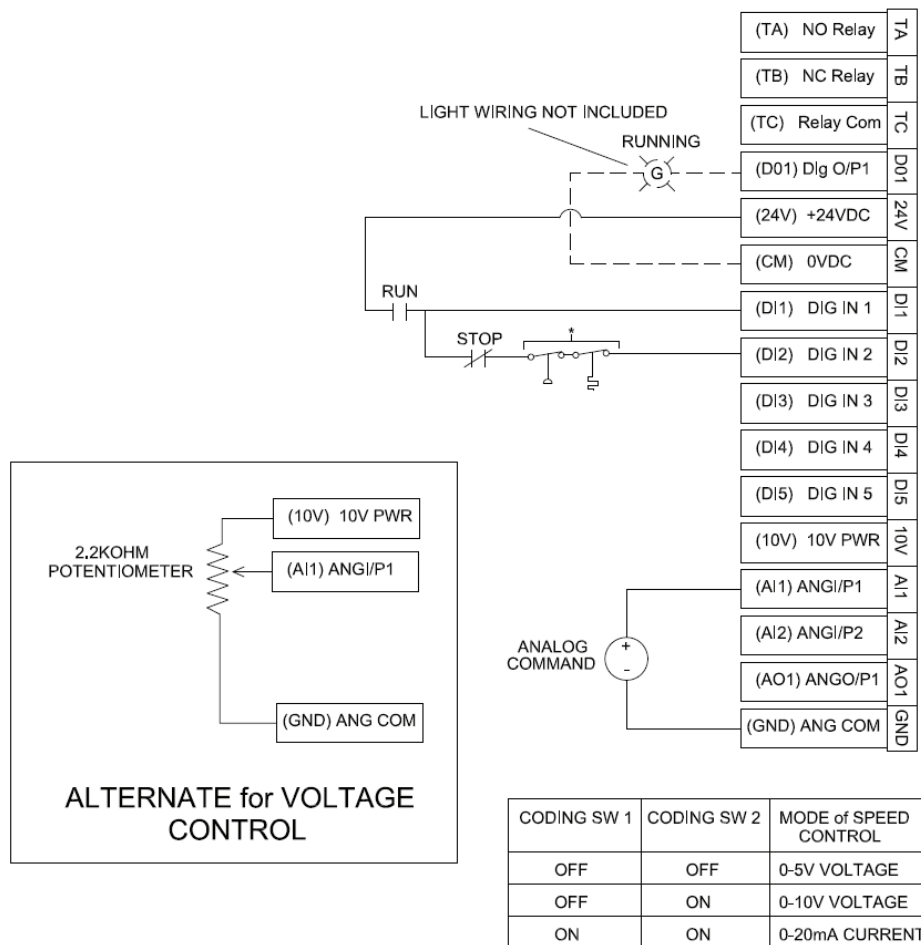

* The default switch setting when ordering voltage control (option V) will be 0-10VDC. If 0-5VDC is required the customer must change the switch settings for 0-5VDC.

If DI2 is not used, install a jumper between DI1 and DI2.

Discrete Speed Control: If option “D” is selected the unit will be configured to operate at 8 different speeds based on the combination of making 3 inputs active. There are also two discrete inputs that need to be wired by the customer to enable the drive. DI1 and DI2 need to be “ON” (held at 24VDC) to start the drive. If either input goes low the unit will stop. See the wiring example below. The unit will be factory set to operate at the speeds shown in the diagram. These speeds can be changed by the customer using the keypad or computer interface (ref to the AC10 operating manual).

CAUTION: Disabling the drive DOES NOT remove power from the motor. High voltage can be present at the motor leads even when the motor is not running. To ensure the motor is safe to wire, make sure the disconnect is locked in the OFF position, incoming power is removed and the AC10’s display and LED’s are off, indicating the capacitors are discharged.

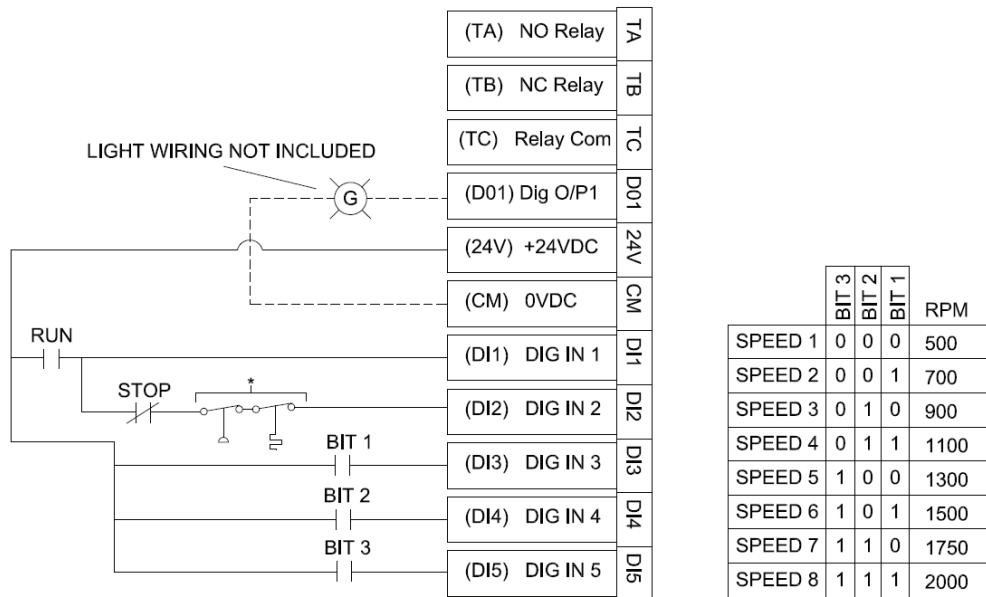

* IF THE POWER UNIT IS EQUIPPED WITH THE "R2" TEMP/LEVEL SWITCH IT COULD BE WIRED IN SERIES WITH THE STOP INPUT AS A WAY TO AUTOMATICALLY STOP THE UNIT ON LOW LEVEL OR HIGH TEMPERATURE. CUSTOMER SUPPLIED WIRING.

If DI2 is not used, install a jumper between DI1 and DI2.

Auto 2 Speed Based on Motor Current: This configuration (option “Q”) will run at full rated speed (1800RPM) and then automatically drop to minimum speed (600RPM) when the motor current exceeds a certain value. This speed change is not internally triggered. It is accomplished using an output wired to an input. The unit will have a jumper wire that connects relay output TA to DI3. When the max current level is exceeded TA turns on, bringing DI3 high. When DI3 is high the unit runs at minimum speed. This configuration works well in clamping circuits where initial cylinder movement is rapid with low resistance followed by stalling at clamping pressure and very little flow. If the jumper between TA and DI3 is removed or controlled externally additional possibilities can be realized based on how the customer manipulates DI3. For example, a pressure switch or PLC could be used alone or with DI3 to reduce speed. There are also two discrete inputs that need to be wired by the customer to enable the drive. DI1 and DI2 need to be “ON” (held at 24VDC) to start the drive. If either input goes low the unit will stop.

Factory settings for option Q: When motor current > 95% FLA, DO1 turns on. See F310 in AC10 manual.

When motor current < 75% FLA, DO1 turns off. See F311 in AC10 manual.

F310 is an absolute number, ie 19 amps.

F311 is a percentage, ie 15%. DO1 turns on when the motor current exceeds 19 amps and turns off when the motor current is less than (19-19x15%) or 16.15 amps.

These values can be changed by the customer using the keypad or computer interface (ref to the AC10 operating manual).

NOTE: If your application requires a lot of force during pre-travel or consumes flow during clamping, the system may hunt as the motor current crosses the MIN and MAX current levels. Option D (speed determined by inputs, not current) may be a better option in these cases.

CAUTION: Disabling the drive DOES NOT remove power from the motor. High voltage can be present at the motor leads even when the motor is not running. To ensure the motor is safe to wire, make sure the disconnect is locked in the OFF position, incoming power is removed and the AC10’s display and LED’s are off, indicating the capacitors are discharged.

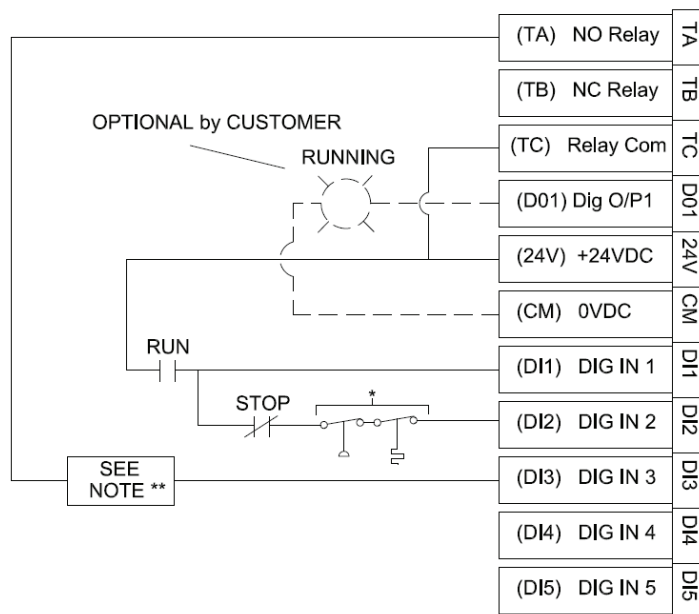

** DI3 COULD INCLUDE A PRESSURE SWITCH OR OTHER SIGNAL TO MANIPULATE WHEN TA IS CONNECTED TO DI3, WHICH TRIGGERS SLOW SPEED, LIMITING POWER CONSUMPTION. IF THE FACTORY JUMPER IS WIRED DIRECTLY BETWEEN TA AND DI3, THE SYSTEM WILL SWITCH TO SLOW SPEED BASED ON ABOVE OPTION DESCRIPTION.

If DI2 is not used install a jumper between DI1 and DI2.

Soft Start: Option “S” is simply a soft start application. When enabled the motor will accelerate to max RPM (factory set at 1800RPM) over 2 secs. This option can help protect the couplings and pump from wear and like all the above options, inrush current is controlled to minimize motor winding stresses. It also gives the pump a better chance to properly prime before full flow is achieved.

CAUTION: Disabling the drive DOES NOT remove power from the motor. High voltage can be present at the motor leads even when the motor is not running. To ensure the motor is safe to wire, make sure the disconnect is locked in the OFF position, incoming power is removed and the AC10’s display and LED’s are off, indicating the capacitors are discharged.

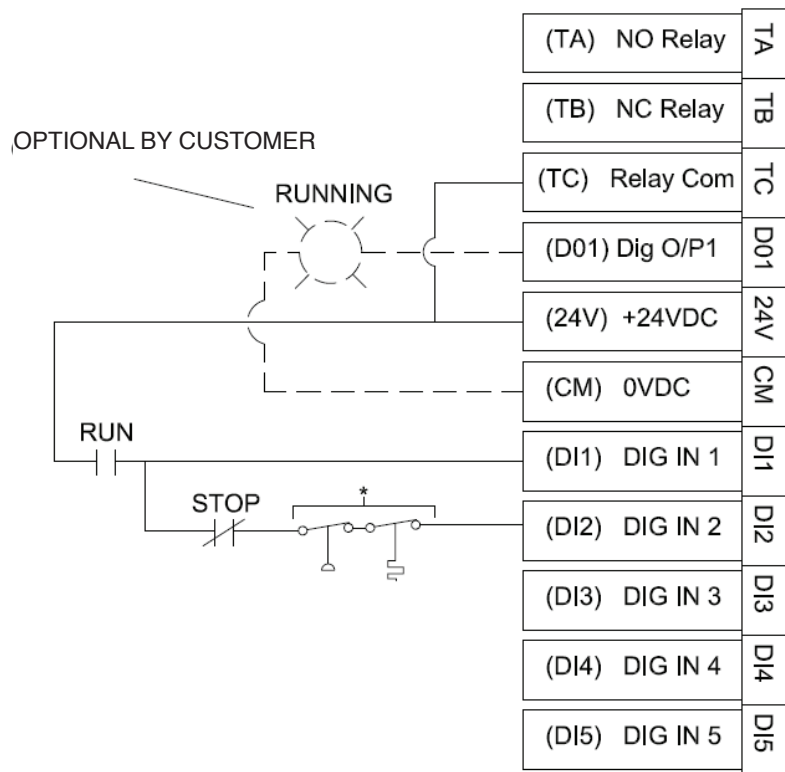

If DI2 is not used, install a jumper between DI1 and DI2.

AC10 Part Numbers:

HP	Voltage	Hp/Voltage	AC 10 Part Numbers
2	2	Incoming Power 230VAC 3 Phase	16G-31-0070-BF-DT
	4	Incoming Power 460VAC 3 Phase	16G-41-0040-BF-DT
3	2	Incoming Power 230VAC 3 Phase	16G-31-0100-BF-DT
	4	Incoming Power 460VAC 3 Phase	16G-41-0065-BF-DT
5	4	Incoming Power 460VAC 3 Phase	16G-41-0090-BF-DT
7.5	4	Incoming Power 460VAC 3 Phase	16G-42-0120-BF-DT
10	4	Incoming Power 460VAC 3 Phase	16G-42-0170-BF-DT
15	4	Incoming Power 460VAC 3 Phase	16G-43-0230-BF-DT
20	4	Incoming Power 460VAC 3 Phase	16G-43-0320-BF-DT

AC10 Power Ratings:

Supply	Part Number	kW	Input Current (A)	Output Current (A)	Input Protection Current	Estimated Efficiency	Inductance of Output Choke (mH)
3Ph 230V	16G-31-0025-BF	0.4	4.3	2.5	8.2	≥95	
	16G-31-0045-BF	0.75	7.6	4.5	11.5	≥95	
	16G-31-0070-BF	1.5	12.0	7	18.2	≥96	
	16G-31-0100-BF	2.2	14.3	10	21.5	≥96	
3Ph 400V	16G-41-0020-BF	0.75	4.1	2	6.5	≥95	
	16G-41-0040-BF	1.5	6.9	4	11.0	≥96	
	16G-41-0065-BF	2.2	9.6	6.5	15.0	≥96	
	16G-41-0080-BF	3.7	11.6	8	18.0	≥96	
	16G-41-0090-BF	4.0	13.6	9	21.0	≥96	
	16G-42-0120-BF	5.5	18.8	12	29.0	≥96	
	16G-42-0170-BF	7.5	22.1	17	34.0	≥96	
	16G-43-0230-BF	11	30.9	23	46.5	≥97	
16G-43-0320-BF	15	52	32	80.0	≥97		

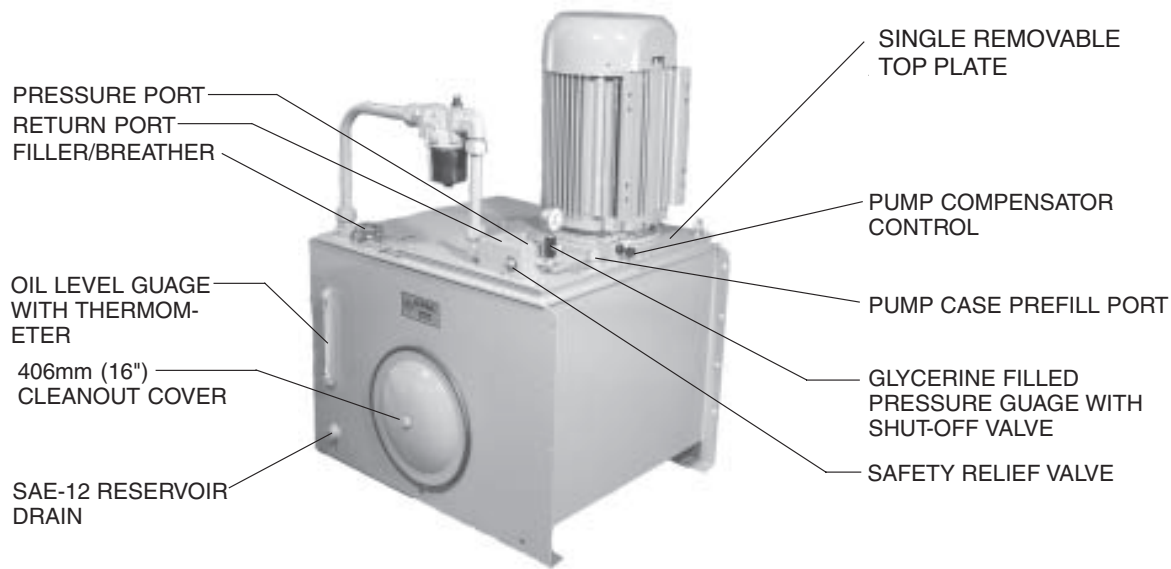

Standard Features

- Vertical Design
- Submerged Pump
- Precision Pump Mounting Adapters
- Suction Strainer
- Glycerine Filled Pressure Gage with Shut Off
- Oil Level Gage with Thermometer
- Remote Compensator and Safety Relief
- Breather and Fill Cap
- 1800 RPM Motor
- Drain Plug
- Clean Out Cover
- Single Removable Topplate
- Extra SAE-20 Return Port
- All Hydraulic Connections SAE Straight Thread

Benefits

- Saves Floor Space
- Positive Pump Inlet
- Longer Pump Life
- Protects Pump from Contamination
- Improved Diagnostics
- Helps to Maintain Trouble-Free Performance
- Protects Against System Shock
- Easy to Fill Tank, Control Ingression of Airborne Contaminants
- More Flow at Less Cost
- Allows Drainage of Fluid
- Easy Access to Inside of Reservoir
- Easy Servicability of Internal Components
- Allows Flexibility for Customer Return Plumbing
- No Leaks

Quick Reference Data Chart

Low Profile V-Pak	Tank Size Liters (Gallon)	Pump Flow LPM (GPM) @ 1800 RPM	Electrical Motors KW (HP)	Maximum BAR (PSI)
V8	302.8 (80)	136.7 (36.1)	5.6 - 30 (7 1/2 - 40)	207 (3000)

Performance Data

Standard Features

- Vertical Design
- Submerged Pump
- Precision Pump Mounting Adapters
- Suction Strainer
- Glycerine Filled Pressure Gage with Shut Off
- Oil Level Gage with Thermometer
- Relief Valve
- External Pump Compensator Control
- Breather and Fill Cap
- 1800 RPM TEFC Motor
- Cleanout Cover
- Pressure and Return Port Block with Safety Relief
- Remote Pump Compensator Control Valve

Options

- D05 (D02) Single Station Manifold with Safety Relief
- D05 (D02), D08 (D06) Multi-Station Manifold with Safety Relief
- Pressure & Return Filters (10 Micron)
- Variety of Manapak Sandwich Valves
- Heat Exchangers (Air/Oil)
- Combination Temp/Float Switch - Temp Fixed
- Single Pressure Remote Compensator
- Single Pressure Remote Compensator with Low Pressure Standby
- Bi-Pressure Remote Compensator
- Bi-Pressure Remote Compensator with Low Pressure Standby
- Load Sensing (Flow Control)-Consult Factory
- Horsepower Limiting-Consult Factory
- Dual Rated 50/60Hz Motors

Specifications

Parker "V-Pak" Hydraulic Power Units are vertical design, 303 liter (80 gallon) reservoirs utilizing Parker Variable Volume Piston Pumps.



Warranty

The hydraulic components on these Parker Power Units are warranted for one year. This warranty may be extended to three years by using and properly maintaining Parker filters.

Schematic Symbol
 (Basic Unit)

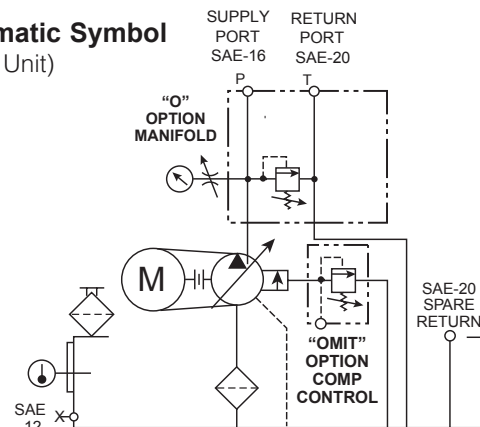

V-PAK BASIC UNIT

NO OPTIONS OR ACCESSORIES
 "OMIT" OPTION PUMP COMPENSATOR
 "O" OPTION MANIFOLD

Installation Data:

See page 19 of this catalog or Parker Installation/ Maintenance Manual for specific recommendations pertaining to start-up, system cleanliness, fluids, temperatures and other important factors relative to proper installation and use of these power units.

Pump Model	Tank Size Liters (Gallon)	Pump Flow LPM (GPM) @ 1800 RPM	Electrical Motors KW (HP)	Maximum BAR (PSI)
V8	302.8 (80)	136.7 (11.0-36.1)	5.6 - 30 (7 1/2 - 40)	207 (3000)

V-Pak Low Profile Ordering Information

Hydraulic Power Units
V-Pak Low Profile Series



Reservoir Size
80 Gallons
(302.8 Liters)



Pressure Control



Pump Control



Pump Flow

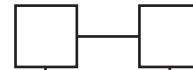

D = Dual Rated*
W = No Motor**



Manifold

Code	Pressure Control
Omit	Single Pressure Remote Compensator
B	Single Pressure Remote Compensator with Low Pressure Standby
BJ	Single Pressure Remote Compensator with Low Pressure Standby, 24 VDC
C	Bi-Pressure Remote Compensator
CJ	Bi-Pressure Remote Compensator, 24VDC
D	Bi-Pressure Remote Compensator with Low Pressure Standby
DJ	Bi-Pressure Remote Compensator with Low Pressure Standby, 24VDC
F	Provision for Customer Supplied Remote Control Relief Valve

Code	Pump Control
Omit	Std. Remote Compensator
A*	Load Sense Flow Control

*Unless otherwise specified, a SAE-6 37° flared port will be supplied for customer connection.

**Consult factory for horsepower and hi-lo pump control options. Lead time is four weeks.

Code	Pump Flow Rate @1800 RPM	Pump Used and Description
15	15.6 GPM (59 LPM)	PVP33 - Std. Remote Compensator
23	23.0 GPM (87 LPM)	PVP48 - Std. Remote Compensator
36	36.1 GPM (137 LPM)	P2075 - Std. Remote Compensator
*	Specify in GPM	Destroyed (Reduced) Flow

*Unless otherwise specified, units are shipped at max. flow rate (GPM) at 1800 RPM.

When reduced flow setting is required, Reduced flows from 22.5 to 8.0 GPM (85.2 to 30.3 LPM), specify in 0.5 GPM increments. Reduced flows from 35.0 to 24.0 GPM (132.5 to 90.8 LPM), specify in 1.0 GPM (3.8 LPM) increments.

Example: V*9.5*-- = PVP33 Pump destroyed to 9.5 GPM (36.0 LPM)
V*A31*-- = P2075 Load Sense Pump destroyed to 31.0 GPM (177.3 LPM)

*Use D prefix to specify dual rated motor. When ordering, D must be followed by the motor model code.

NOTE:

1. Manifolds are mounted vertically. Bottom station is number 1.
2. M5-3 and 5 station available. M8-2 station available.

= Omit if not required

If No Motor or Dual Rated	Code	Electric Motor Description HP (KW) - RPM Frame Phase
W	M	213TC (no motor)
	M	7.5 (5.6) - 1725 - 213TC - 3
D	M	7.5 (5.6) - 1725 - 213TC - 3 DUAL RATED
W	N	215TC (no motor)
	N	10 (7.5) - 1725 - 215TC - 3
D	N	10 (7.5) - 1725 - 215TC - 3 DUAL RATED
W	P	254TC (no motor)
	P	15 (11.2) - 1725 - 254TC - 3
D	P	15 (11.2) - 1725 - 254TC - 3 DUAL RATED
W	S	256TC (no motor)
	S	20 (14.9) - 1725 - 256TC - 3
D	S	20 (14.9) - 1725 - 256TC - 3 DUAL RATED
W	Q	284TC (no motor)
	Q	25 (18.6) - 1725 - 284TC - 3
D	Q	25 (18.6) - 1725 - 284TC - 3 DUAL RATED
W	R	286TC (no motor)
	R	30 (22.4) - 1725 - 286TC - 3
D	R	30 (22.4) - 1725 - 286TC - 3 DUAL RATED
W	V	324TC (no motor)
	V	40 (29.8) - 1725 - 324TC - 3
D	V	40 (29.8) - 1725 - 324TC - 3

Three phase electric motors are rated as follows:
208-230/460V, 3PH, TEFC - 60 Hertz 1800 RPM 1.15 SF

• Dual rated motors include the 60Hz ratings plus 190/380V 50Hz (1.0SF) 1450RPM 10:1CT/20:1VT INVERTER RATED UR/CSA/CSA EEV/CE

• Dual rated motors may have longer than standard leadtime. Options G & K3 are dual rated as standard.

Consult factory for other motor speeds (RPM) and voltages.

** Use W prefix when no motor is required on unit.

When ordering, W must be followed by motor model code equivalent to frame size of motor to be used.

DO NOT USE "W" and "D" together I.E: 213TC unit with no motor is called out "WM".

Code	Porting Block/Subplate or Manifold Type	Supply/Return Port or Actuator Port Size	Other
Omit	Pressure and Return Port Block with Safety Relief Valve	P Port SAE-16 T Port SAE-20	None
S5	D05 Single Station Subplate with Safety Relief Valve	A & B Ports SAE-10 Str. Thr'd	None
M5* (2)	D05 Multistation Parallel Circuit Manifold with Safety Relief and Pump Compensator Valves	A & B Ports SAE-8 Str. Thr'd	None
M82 (2)	D08 Two Parallel Circuit Manifold with Safety Relief and Pump Compensator Valves	A & B Ports SAE-16 Str. Thr'd	Y Port SAE-8 Str. Thr'd

*When ordering Multi-Station Manifolds, the number of stations must be specified. If valves are to be mounted, specify the valves and sequence, if the model code exceeds 25 digits, call factory.

Example: V815QM53BCB1

3 Station D05 Manifold
Station #1: B
Station #2: C
Station #3: B1

Example: V815QM55B1B1CBC

5-Station D05 Manifold
Station #1: B1
Station #2: B1
Station #3: C
Station #4: B
Station #5: C



V-Pak Low Profile Ordering Information



Directional Control Valve



Manapak Control Valves*



Options and Accessories

Code	Directional Control Valve Model Number	NFPA Mounting Pad	Nominal Flow GPM (LPM)	Description	Circuit Symbol
B	D3W1CNYCCF	D05	20	Double (Spr. Ctr)	
C	D3W4CNYCCF	D05	15	Double (Spr. Ctr)	

Code	Manapak Control Valves Function	Valve Model Number	NFPA Mounting Pad	Nominal Flow GPM (LPM)	Circuit Symbol
1	FM3DDKN	D05	D05	7 (26.5)	
3	CPOM3DDN	D05	D05	7 (26.5)	

*Manapak valves mounted in order of callout. First valve will be nearest DCV; last valve will be on manifold.

Code	Options and Accessories		
	Function	Model Number	Technical Data
A*	Continuous Pump Case Cooling	RM-08-2-2	Air/Oil: .8Hp (.6KW) Rej Available on 7.5Hp thru 25Hp (5.6-18.5KW) motors
B*	Continuous Pump Case Cooling	RM-19-2-2	Air/Oil: 1.5Hp (1.1KW) Rej
C#^	Filter Cooling Loop	AOC-22-2-1PH 40CN205Q	Air/Oil w/1PH Motor: Oil flow 8GPM (30LPM) 4.5Hp (3.3KW) heat rejection Includes 3/4" weld coupling for customer supplied device (Temp switch for fan)
E#^	Return Line Heat Exchanger	EKS-708-T	Water/oil: 17Hp (12.7 KW)Rej @ 20GPM Oil Flow 2:1 Flow ratio Max oil Flow 60GPM Max water flow 12 GPM Includes 3/4" weld coupling for customer supplied device
F^	Water valve/ bulbwell	65253 + bulbwell + 3/4" weld coupling	If ordered without option E this option will only include the 3/4" weld coupling.
H	Pressure Filter	30P210QM250NN1	10 Micron Microglass II Dual Element, Mechanical Indicator
J	2" Weld coupling for customer supplied heater		
K	Check Valve Pump Outlet	493-16-D1-2	5 PSI (0.3 bar) Cracking Pressure
L	Bypass Check	C2020S65	65 PSI (4.6 bar) Cracking Pressure
N	Return Filter	40CN210Q	10 Micron Microglass II Dual Element, Mechanical Indicator** (8 PSID)
R1	Combination Float/Temp. Switch N.O. Float Up	877501	Fixed Temp at 65°C (149°F) Close @ Low Level and/or 65°C (149°F) (N.O.)
R2	Combination Float/Temp. Switch N.C. Float Up	877502	Fixed Temp at 65°C (149°F) Open @ Low Level and/or 65°C (149°F) (N.C.)

*Heat rejection based on 72 deg F differential between the oil and the ambient temperature.

#Heat rejection based on 40deg F differential between transfer medium.

^ May require longer than standard lead time.

DO NOT select more than one offline loop, A or B or C. C & E cannot be selected together.

= Omit if not required

Dimensions – Basic V-Pak Low Profile

Shown with “Omit” Option Manifold

Inch equivalents for millimeters dimensions are shown in (**). Installation information is for reference only, consult factory or visit Parker's Econfigurator for detailed information.

Motor Code	Motor Description KW(HP)-RPM-Frame-Type	Dimension	
		"A"	"B"
M	7.5 (5.6) - 1725 - 213TC - 3	458(18)	N/A
N	10 (7.5) - 1725 - 215TC - 3	473 (18.6)	N/A
P	15 (11.2) - 1725 - 254TC - 3	522 (20.5)	48 (1.88)
S	20 (14.9) - 1725 - 256TC - 3	522 (20.5)	48 (1.88)
Q	25 (18.6) - 1725 - 284TC - 3	611 (24)	51 (2.0)
R	30 (22.4) - 1725 - 286TC - 3	611 (24)	51 (2.0)
V	40 (29.8) - 1725 - 324TC - 3	789 (31)	144 (5.69)

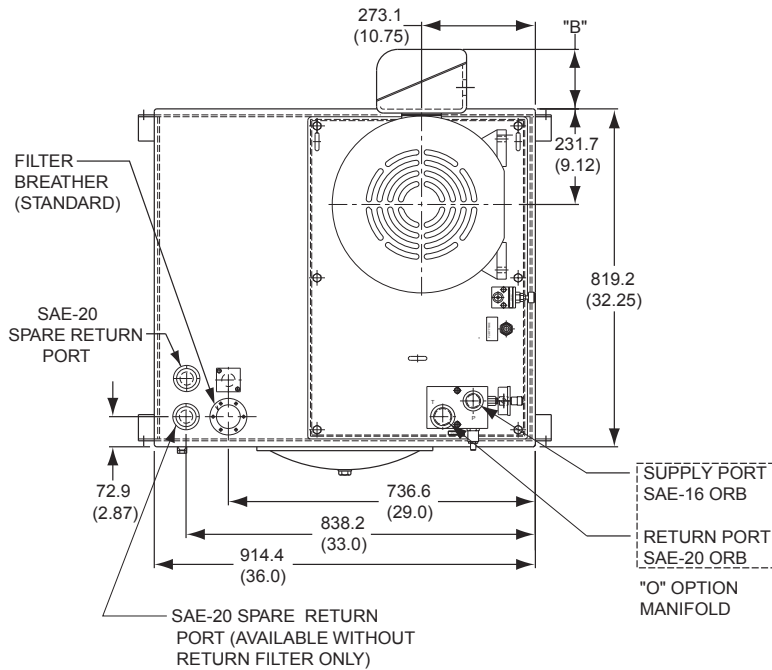

* Reference dimension consult factory if critical to application.

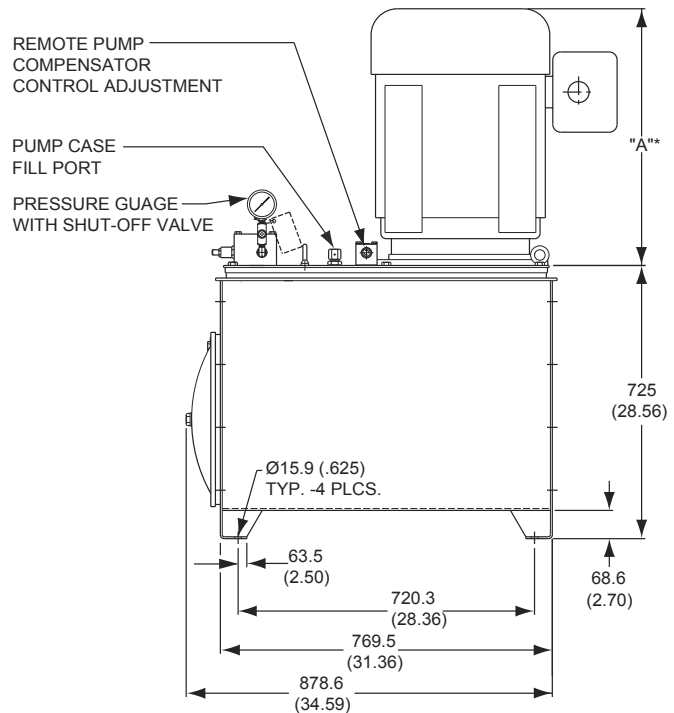
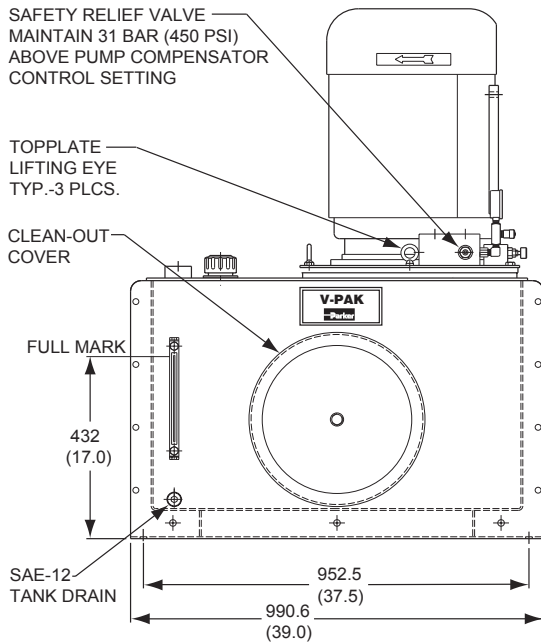

V-Pak Low Profile S5 Manifold Options

Inch equivalents for millimeters dimensions are shown in (**)

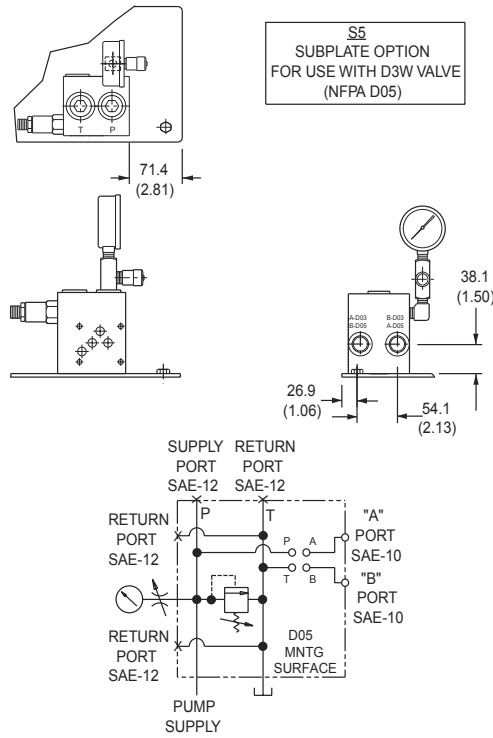

V-Pak Low Profile M53/M55 & M82 Manifold Options

Inch equivalents for millimeters dimensions are shown in (**).

"M53/M55 Option"

M53 AND M55
 3 AND 5 STATION MANIFOLD OPTIONS
 FOR USE WITH NFPA D05 VALVES

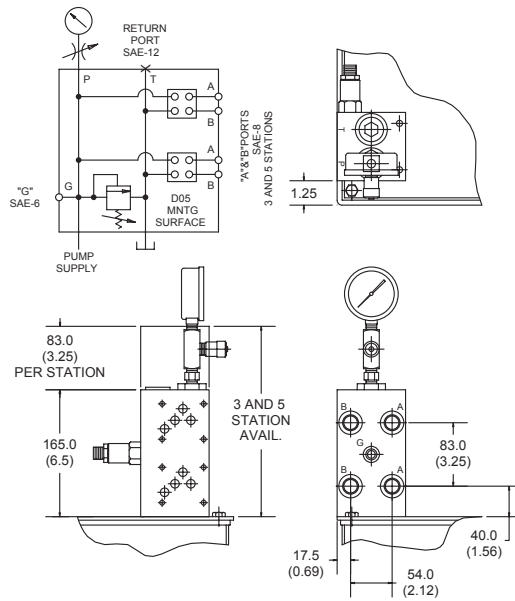

"M82 Option"

M82
 2 STATION MANIFOLD OPTION
 FOR USE WITH NFPA D08 VALVES
 SAE-8 "Y" PORT, NO "X" PORT

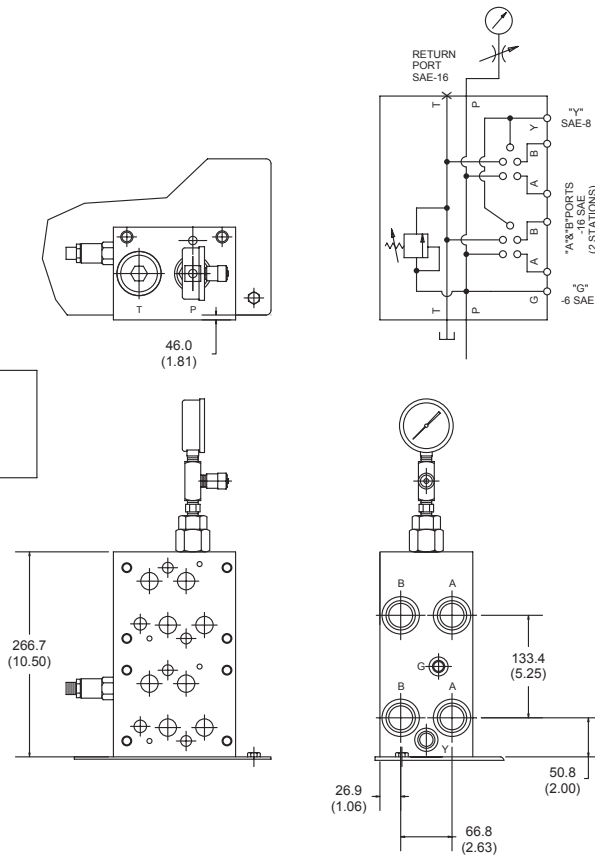

V-Pak Low Profile – Compensator Options

Inch equivalents for millimeters dimensions are shown in (**)

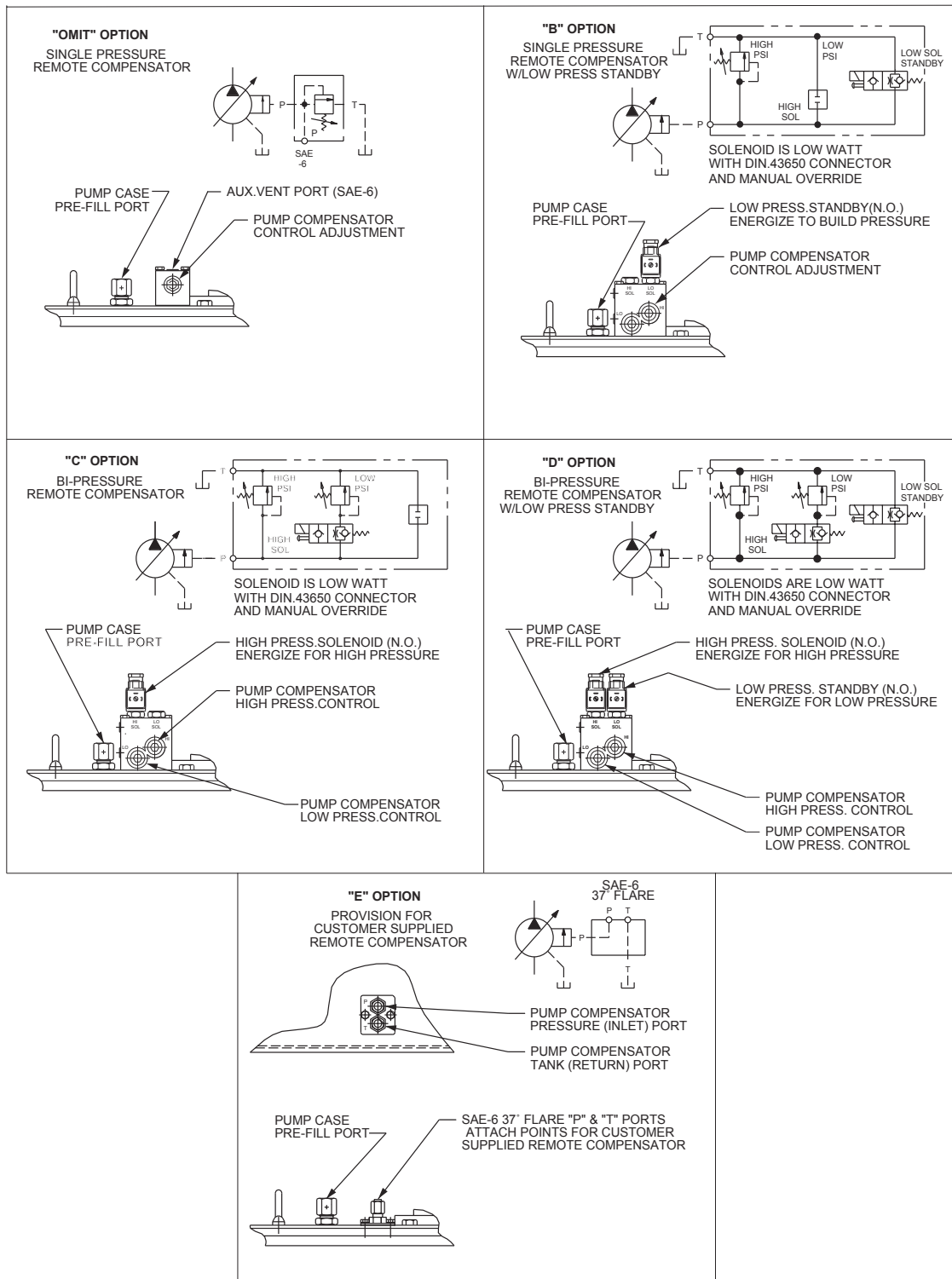

**Accessory Options
 V-Pak LOW PROFILE**

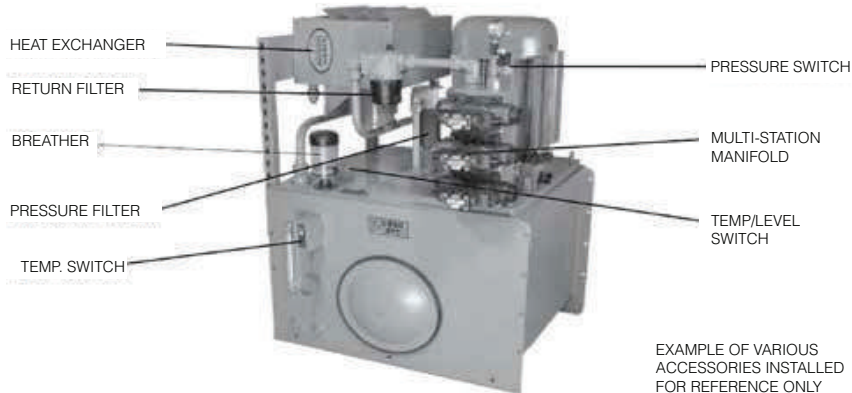

EXAMPLE OF VARIOUS ACCESSORIES INSTALLED FOR REFERENCE ONLY

SCHEMATIC - BASIC UNIT WITH ACCESSORIES

- | | |
|---|---|
| OPTION (A) PUMP CASE COOLING (7.5HP-25HP ONLY) | OPTION (H) PRESSURE FILTER |
| OPTION (B) PUMP CASE COOLING | OPTION (J) 2" COUPLING FOR C/S HEATER |
| OPTION (C) SYSTEM COOLING/FILTER LOOP | OPTION (K) PUMP OUTLET CHECK VALVE |
| | OPTION (L) BYPASS CHECK-RETURN HT. EX. ONLY |
| OPTION (E) RETURN LINE WATER/OIL HEAT EXCHANGER | OPTION (N) RETURN FILTER-DUAL ELEMENT |
| OPTION (F) WATER TEMPERATURE MODULATING VALVE | OPTION (R) COMBINATION LEVEL/TEMPERATURE SWITCH |

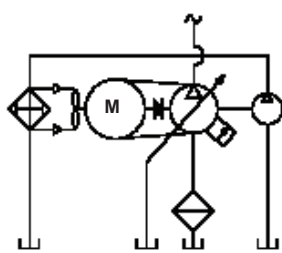

(A) (B) OPTION
 4.5 GPM @ 1.750 RPM

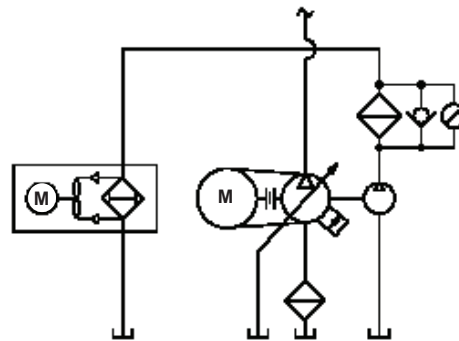

(C) OPTION
 4.5 GPM @ 1.750 RPM

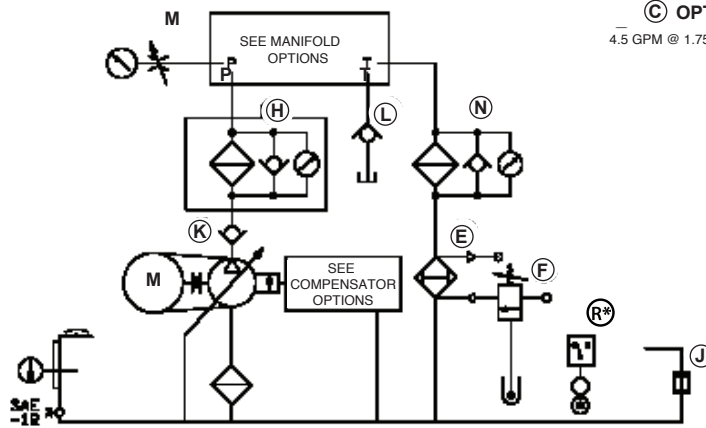

HYDRAULIC SCHEMATIC

Dimensions – Accessories

V8 Reservoir with "Omit" Manifold Shown

Inch equivalents for millimeters dimensions are shown in (**). Installation information is for reference only. Consult factory or visit Parker's Econfigurator for detailed information.

HEAT REMOVAL	OPTION A	.6 KW (.80 HP*)
HEAT REMOVAL	OPTION B	1.1 KW (1.5 HP*)

*Performance data are based on 100SSU oil leaving the cooler 4°C (40°F) higher than the ambient air temperature used for cooling.

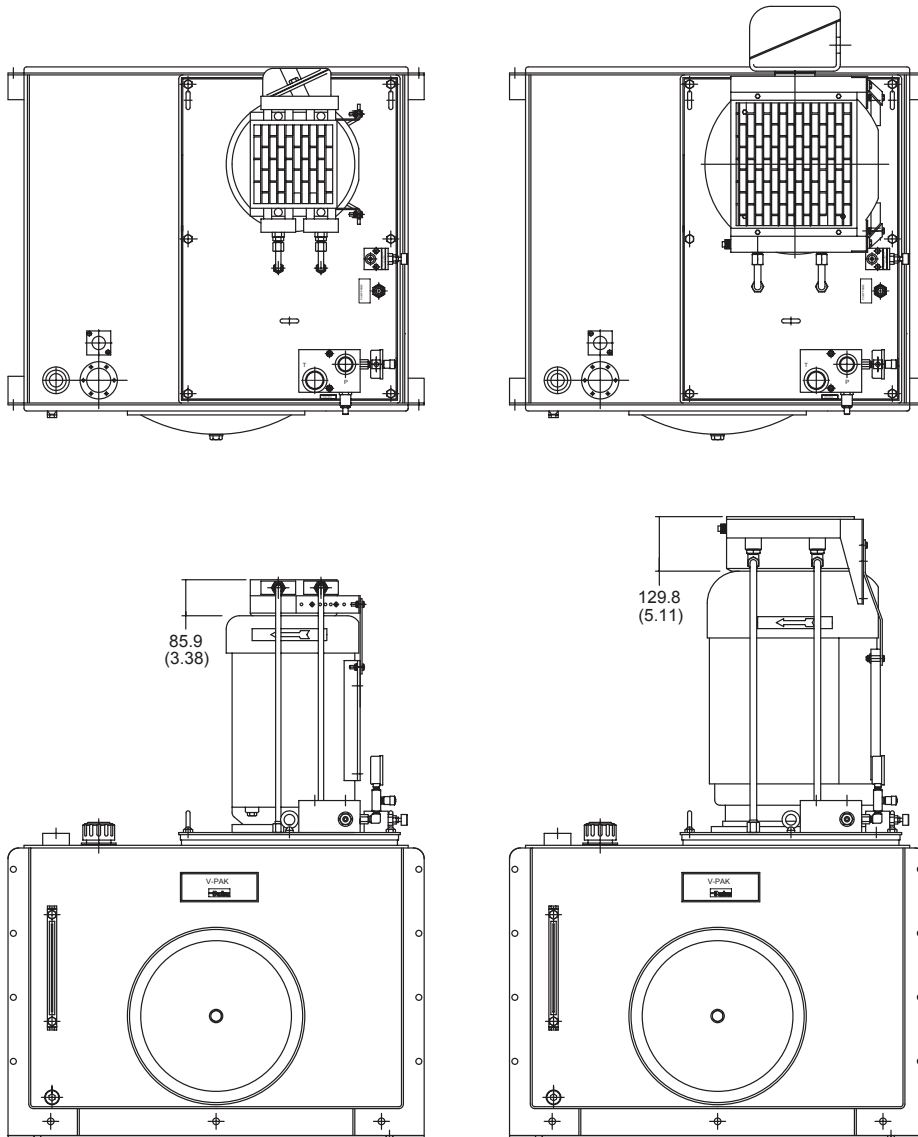

Option "A" Cooling Loop
5.6 KW - 18.6 KW (7.5 HP - 25 HP) ONLY

Option "B" Cooling Loop

Dimensions – Accessories

V8 Reservoir with "Omit" Manifold Shown

Inch equivalents for millimeters dimensions are shown in (**)

Ordering Note: Units with PVP76 pumps and requiring options "A", "B" or "C" can only be ordered with V8 (302.8 L/80 Gal.) reservoir.

HEAT REMOVAL	OPTION C	3.4 KW (4.5 HP*)
--------------	----------	------------------

*Performance data are based on 100SSU oil leaving the cooler 4°C (40°F) higher than the ambient air temperature used for cooling.

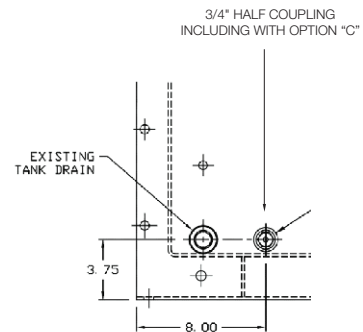
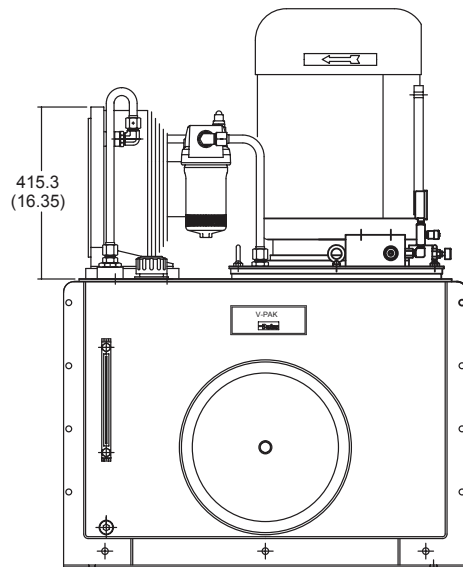
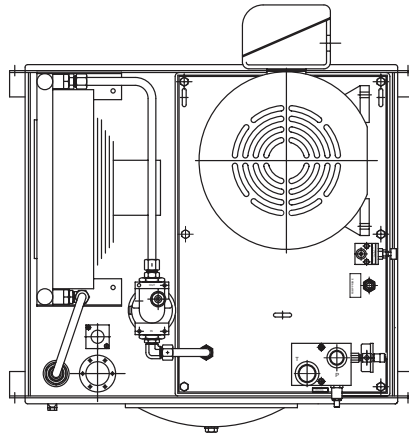

Option "C" System Cooling/Filter Loop

Dimensions Accessories

V8 Reservoir with E, F, H, J, N & R Options Shown

Inch equivalents for millimeters dimensions are shown in (**).

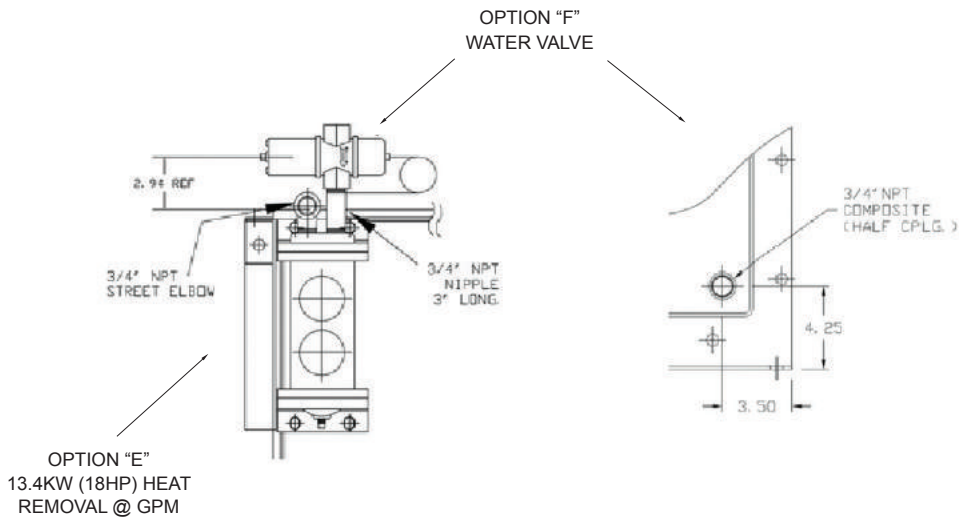
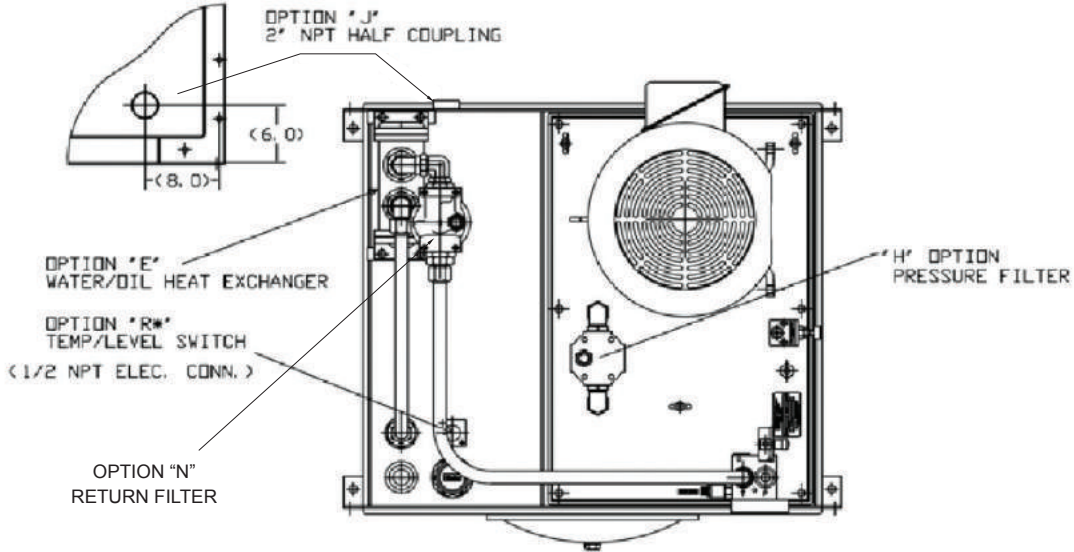

Performance Data — Maximum Working Pressure

**** Represents maximum operating pressure with pump/motor combination. This will be the maximum relief valve or compensator setting.

**** Represents maximum operating pressure with pump/motor combination. When used on power units products, the highest relief valve or compensator setting will be 3000 PSI.

**V-Pak Low Profile - Pump/Motor Combinations Maximum Operating Pressure
 Bar (PSI)**

PUMP	FLOW LPM (GPM) @ 1725 RPM	5.6 KW (7.5 HP)	7.5 KW (10 HP)	11.2 KW (15 HP)	14.9 KW (20 HP)	18.6 KW (25 HP)	22.3 KW (30 HP)	29.8 KW (40 HP)
PVP33	41.6 (11.0)	75.2 (1090)	98.6 (1430)	146.9 (2130)	194.4 (2820)	239.2 (3470)		
PVP33	43.5 (11.5)	72.4 (1050)	95.1 (1380)	141.3 (2050)	186.8 (2710)	230.3 (3340)		
PVP33	45.4 (12.0)	69.6 (1010)	91.7 (1330)	135.8 (1970)	180 (2610)	222 (3220)		
PVP33	47.3 (12.5)	66.9 (970)	88.3 (1280)	131 (1900)	173.7 (2520)	213.7 (3100)		
PVP33	49.2 (13.0)	64.8 (940)	85.5 (1240)	126.9 (1840)	167.5 (2430)	206.8 (3000)	247.5 (3590)	
PVP33	51.1 (13.5)	62.7 (910)	82.7 (1200)	122.7 (1780)	162 (2350)	200 (2900)	239.2 (3470)	
PVP33	52.9 (14.0)	60.7 (880)	80 (1160)	118.6 (1720)	157.2 (2280)	193.7 (2810)	232.4 (3370)	
PVP33	54.8 (14.5)	59.3 (860)	77.9 (1130)	115.1 (1670)	152.4 (2210)	188.2 (2730)	224.8 (3260)	
PVP33	56.7 (15.0)	57.2 (830)	75.2 (1090)	111.7 (1620)	147.5 (2140)	182.7 (2650)	218.6 (3170)	

Performance Data — Maximum Working Pressure

**** Represents maximum operating pressure with pump/motor combination. This will be the maximum relief valve or compensator setting.

**** When used on power unit products, the highest relief valve setting will be 3000 PSI due to other component limitations.

**V-Pak Low Profile - Pump/Motor Combinations Maximum Operating Pressure
 Bar (PSI)**

PUMP	FLOW LPM (GPM) @1725 RPM	5.6 KW (7.5 HP)	7.5 KW (10 HP)	11.2 KW (15 HP)	14.9 KW (20 HP)	18.6 KW (25 HP)	22.3 KW (30 HP)	29.8 KW (40 HP)
PVP48	58.6 (15.5)	53.8 (780)	70.3 (1020)	103.4 (1500)	137.9 (2000)	170.3 (2470)	203.4 (2950)	270.2 (3920)
PVP48	60.5 (16.0)	53.1 (770)	68.9 (1000)	101.4 (1470)	133.8 (1940)	166.2 (2410)	198.6 (2880)	263.4 (3820)
PVP48	62.4 (16.5)	57.1 (750)	67.6 (980)	98.6 (1430)	130.3 (1890)	162 (2350)	193.1 (2800)	256.5 (3720)
PVP48	64.3 (17.0)	50.3 (730)	65.5 (950)	96.5 (1400)	126.9 (1840)	157.9 (2290)	188.2 (2730)	249.6 (3620)
PVP48	66.2 (17.5)	49 (710)	64.1 (930)	93.8 (1360)	124.1 (1800)	153.8 (2230)	183.4 (2660)	243.4 (3530)
PVP48	68.1 (18.0)	48.3 (700)	62.8 (910)	91.7 (1330)	121.3 (1760)	150.3 (2180)	179.3 (2600)	237.9 (3450)
PVP48	70.0 (18.5)	46.9 (680)	61.4 (890)	89.6 (1300)	118.6 (1720)	146.9 (2130)	175.1 (2540)	232.4 (3370)
PVP48	71.9 (19.0)	46.2 (670)	60 (870)	87.6 (1270)	115.8 (1670)	143.4 (2080)	171 (2480)	226.8 (3290)
PVP48	73.8 (19.5)	45.5 (660)	58.6 (850)	86.2 (1250)	113.1 (1640)	140 (2030)	167.5 (2430)	222 (3220)
PVP48	75.7 (20.0)	44.1 (640)	57.2 (830)	84.1 (1220)	110.3 (1600)	137.2 (1990)	163.4 (2370)	216.5 (3140)
PVP48	77.6 (20.5)	43.4 (630)	56.5 (820)	82 (1190)	108.2 (1570)	134.4 (1950)	160 (2320)	212.4 (3080)
PVP48	79.4 (21.0)	42.7 (620)	55.2 (800)	80.7 (1170)	106.2 (1540)	131.7 (1910)	157.2 (2280)	206.8 (3000)
PVP48	81.3 (21.5)	42.1 (610)	54.5 (790)	79.3 (1150)	104.1 (1510)	128.9 (1870)	153.8 (2230)	203.4 (2950)
PVP48	83.2 (22.0)	41.4 (600)	53.8 (780)	77.9 (1130)	102 (1480)	126.2 (1830)	151 (2190)	199.3 (2890)
PVP48	85.1 (22.5)	40.7 (590)	52.4 (760)	75.8 (1100)	100 (1450)	124.1 (1800)	147.5 (2140)	195.8 (2840)
PVP48	87.0 (23.0)	40 (580)	51.7 (750)	74.5 (1080)	97.9 (1420)	121.3 (1760)	144.8 (2100)	191.7 (2780)

Performance Data – Maximum Working Pressure

**** Represents maximum operating pressure with pump/motor combination. This will be the maximum relief valve or compensator setting.

**** Represents maximum operating pressure with pump/motor combination. When used on power unit products this will represent a 207 bar (3000 psi) relief valve or compensator setting.

**V-Pak Low Profile - Pump/Motor Combinations Maximum Operating Pressure
Bar (PSI)**

PUMP	FLOW LPM (GPM) @ 1725 RPM	5.6 KW (7.5 HP)	7.5 KW (10 HP)	11.2 KW (15 HP)	14.9 KW (20 HP)	18.6 KW (25 HP)	22.3 KW (30 HP)	29.8 KW (40 HP)
PVP76	90.8 (24.0)	20.7 (300)	31.7 (460)	55.2 (800)	78.6 (1140)	100 (1450)	121.3 (1760)	167.2 (2425)
PVP76	94.6 (25.0)	20 (290)	31 (450)	53.4 (775)	75.8 (1100)	96.5 (1400)	117.2 (1700)	160.3 (2325)
PVP76	98.4 (26.0)	18.6 (270)	29.6 (430)	52.4 (760)	73.8 (1070)	94.5 (1370)	113.8 (1650)	155.8 (2260)
PVP76	102.2 (27.0)	17.9 (260)	29.3 (425)	50.3 (730)	71 (1030)	91.4 (1325)	113.8 (1650)	155.8 (2260)
PVP76	106.0 (28.0)	17.6 (255)	27.6 (400)	48.3 (700)	68.3 (990)	88.3 (1280)	106.5 (1545)	144.1 (2090)
PVP76	109.8 (29.0)	17.2 (250)	26.9 (390)	46.5 (675)	65.5 (950)	86.9 (1260)	104.5 (1515)	140.7 (2040)
PVP76	113.6 (30.0)	-	26.9 (390)	45.5 (660)	63.8 (925)	83.4 (1210)	103.4 (1500)	137.9 (2000)
PVP76	117.3 (31.0)	-	25.9 (375)	43.8 (635)	61.4 (890)	80.7 (1170)	97.9 (1420)	132.4 (1920)
PVP76	121.1 (32.0)	-	24.8 (360)	42.7 (620)	60.3 (875)	78.6 (1140)	95.1 (1380)	128.6 (1865)
PVP76	124.9 (33.0)	-	23.4 (340)	41.4 (600)	57.9 (840)	75.8 (1100)	92.4 (1340)	124.8 (1840)
PVP76	128.7 (34.0)	-	22.4 (325)	39.6 (575)	56.9 (825)	74.1 (1075)	90.3 (1310)	121.7 (1765)
PVP76	132.5 (35.0)	-	21.4 (310)	36.5 (530)	55.2 (800)	70.7 (1025)	87.9 (1275)	118.9 (1725)
PVP76	136.7 (36.0)	-	20.7 (300)	35.2 (510)	53.1 (770)	68.9 (1000)	84.8 (1230)	111 (1610)

V-Pak Low Profile Performance Data

Fluid Standard Hydraulics Oil 100 SSU @ 49°C (120°F)

Flow, Horsepower and Efficiency Charts

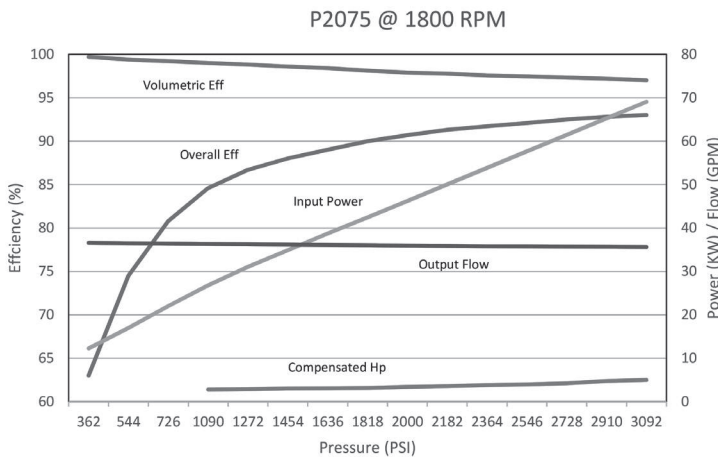
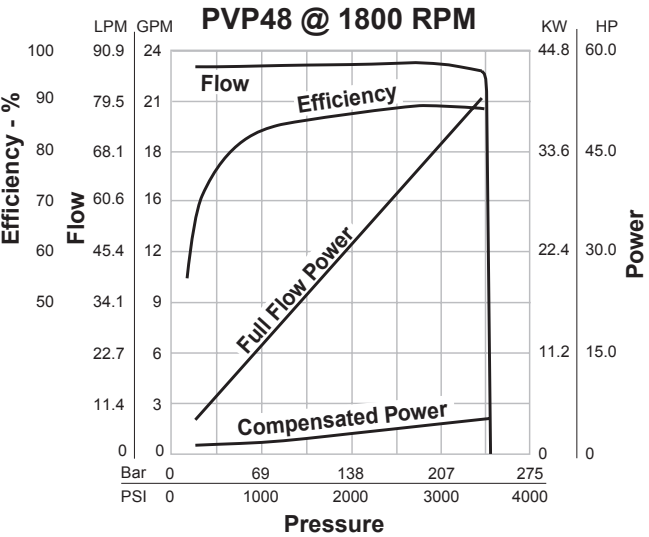
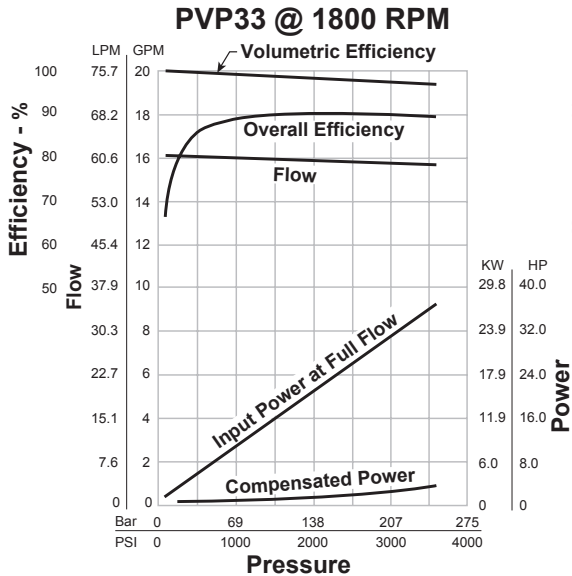

NOTE: The efficiencies and data in the graph are good only for pumps running at 1800 RPM and stroked to maximum. To calculate approximate horsepower for the other conditions, use the following formula:

$$HP = \left[\frac{Q \times (PSI)}{1714} \right] + (CHp)$$

Actual GPM is directly proportional to drive speed and maximum volume setting. Flow loss, however, is a function of pressure only.

WHERE:

- Q = Actual Output Flow in GPM
- PSI = Pressure at Pump Outlet
- CHp = Input Horsepower @ Full Compensation @ 1800 RPM (from graph read at operating pressure)

NOTE: Maximum input HP to the pump may exceed electric motor drive capability. Select motor size (HP) to exceed application requirements (HP).

V-Pak Low Profile Performance Data — Heat Exchangers

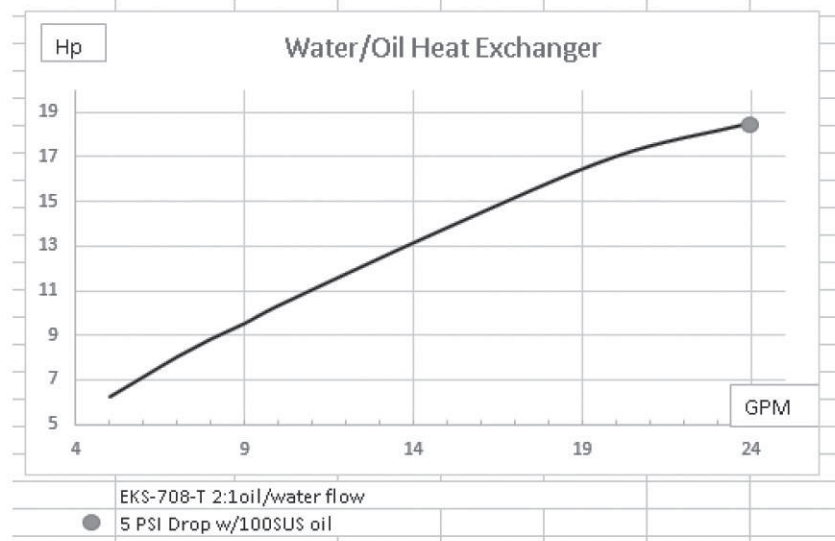

RESERVOIR SIZE LITERS (GALLONS)	
	303 (80)
KW (HP) REMOVAL	.89 (1.2)

Heat removal is based on static ambient air of 29°C (85°F) and max. oil temperature of 57°C (135°F).



Operating Notes

- Jog the electric motor once and verify that the electric motor is rotating in the same direction as the arrow on the electric motor housing. If direction is incorrect, reverse two of the three leads on a 3-phase electric motor.
- D & H-Pak power units are tested and relief valve is set at maximum pressure of the pump/motor combination.
- V-Pak power units are tested and pressure control valves are factory preset. If adjustments are needed, follow the procedure below: Begin adjusting relief valve and pump compensator control valve to increase pressure gradually. (**NOTE:** Always set relief valve 250 PSI higher than pump compensator pressure control valve or severe overheating will occur.)
- If pump fails to prime, vent pump discharge to atmosphere to establish fluid flow.
- Reservoir temperature should not exceed 66°C (150°F). System reliability and component service life will be reduced when system is operated at higher temperature.
- Clean fluid = improved system reliability and longer component service life, change filter elements whenever filter indicators indicate a dirty element condition.

- It is recommended that every 4,000 operating hours or once a year, whichever occurs first, the filler/breather cap and suction strainer should be replaced.

Fluid Recommendations

Premium quality hydraulic oil with a viscosity range between 150-250 SSU (30-50 cst.) at 100°F (38°C). Normal operating viscosity range between 80-1000 SSU (17-180 cst.). Maximum start-up viscosity is 4000 SSU (1000 cst.).

NOTE: Consult Parker when exceeding 160°F (71°C) operation. Oil should have maximum anti-wear properties, rust and oxidation treatment.

Filtration

For maximum pump and system component life, the system should be protected from contamination at a level not to exceed 125 particles greater than 10 microns per milliliter of fluid. (SAE Class 4 / ISO 16/13.) Due to the nature of variable displacement pumps, variations in pump inlet conditions, fluid acceleration losses, system aeration, and duty cycle must be carefully considered before specifying suction line filtration. Contact your Parker representative for assistance.

NOTE: For additional information refer to latest edition of Bulletin No. HY13-2600-550-xxx..

The totally enclosed pump mounting bracket offers precision shaft alignment and safety from the rotating shafts and coupling. The bracket is designed to mount on the motor face with the motor coupling half secure to the shaft. Then the pump, with its coupling half secure on the pump shaft, is mounted and the coupling halves are engaged. This will require proper spacing of the coupling prior to installation and a coupling with an outside diameter less than "P" dimension. If the coupling selected cannot be assembled this way, both coupling halves must be installed on the motor shaft. Next, mount the adapter on the motor. Then the pump can be mounted and the coupling secured to the pump by using the access slot to tighten the pump shaft coupling set screw.

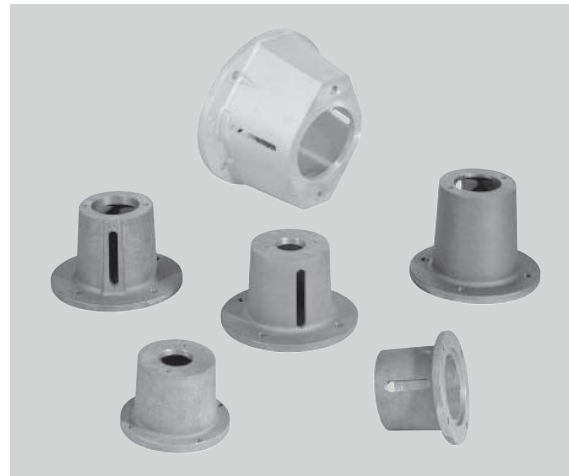

Dimensions*
Pump Mounting Adapter

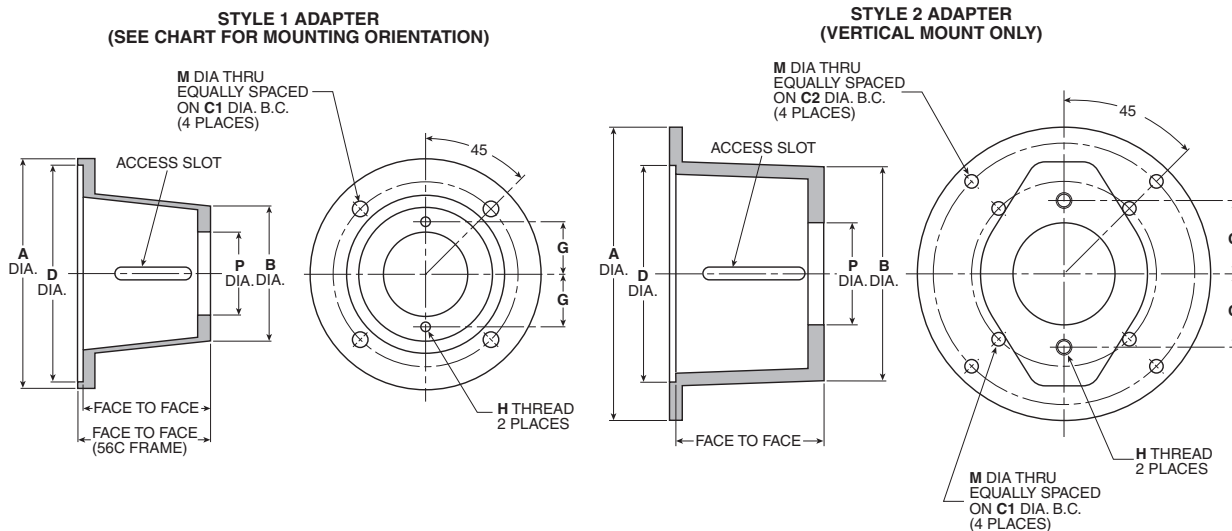

Model Number	Pump Mounting	Motor Mounting	A	B	C1	C2	D	Face to Face	G	H	M	P	Vertical Mounting	Horizontal Mounting	Style	Weight
876631	SAE AA	56C	6.7	5.0	5.88	N/A	4.50	3.50	1.63	3/8-16	0.44	2.00	YES	YES	1	3 lb.
876632	SAE AA	182TC/256TC	9.0	5.3	7.25	N/A	8.50	5.00	1.63	3/8-16	0.56	2.00	YES	YES	1	4 lb.
876633	SAE A	56C	6.7	5.0	5.88	N/A	4.50	4.25	2.10	3/8-16	0.44	3.25	YES	YES	1	4 lb.
876634	SAE A	182TC/256TC	9.0	5.3	7.25	N/A	8.50	5.00	2.10	3/8-16	0.56	3.25	YES	YES	1	4 lb.
876635	SAE A	182TC/256TC	9.0	5.3	7.25	N/A	8.50	5.88	2.10	3/8-16	0.56	3.25	YES	YES	1	5 lb.
875343	SAE B	182TC/256TC	11.4	9.0	7.25	10.25	8.50	5.75	2.88	1/2-13	0.53	4.00	YES	NO	2	7 lb.
875344	SAE B	182TC/256TC	11.4	9.0	7.25	10.25	8.50	6.81	2.88	1/2-13	0.53	4.00	YES	NO	2	8 lb.
876683	SAE B	182TC/256TC	9.0	8.8	7.25	N/A	8.50	6.38	2.88	1/2-13	0.53	4.00	NO	YES	1	7 lb.
876684	SAE C	182TC/256TC	9.0	9.3	7.25	N/A	8.50	6.69	3.56	5/8-11	0.53	5.00	NO	YES	1	20 lb.

* All dimensions are in inches.

NOTE: It is the responsibility of the user to check the listed dimensions to ensure suitability of mounting adapter with pump/coupling/motor combination.



Application Formulas

- 1 GPM at 1500 PSI = 1 HP (General Rule)
- 1 Gallon = 231 Cubic Inches (3.7854 Liters)
- 1 Gallon Oil = 7.08 Lbs.
- 1 bar = 14.5 PSI
- 25.4mm = 1 Inch
- 1 HP = 42.4 BTU/Min.
- 1 Gallon = 3.7854 Liters

$$\text{HP} = \frac{\text{GPM} \times \text{PSI}}{1714 \times \text{Pump Efficiency}}$$

$$\text{PSI} = \frac{1714 \times \text{Pump Efficiency} \times \text{HP}}{\text{GPM}}$$

$$\text{GPM} = \frac{1714 \times \text{Pump Efficiency} \times \text{HP}}{\text{PSI}}$$

$$\text{HP} = \frac{\text{Torque (in.-lbs.)} \times \text{RPM}}{63025}$$

$$\text{Torque} = \frac{\text{HP} \times 63025}{\text{RPM}}$$

$$\text{RPM} = \frac{\text{HP} \times 63025}{\text{Torque}}$$

Motor Information

- At 440V — 3-Phase Motor Draws 1.25 AMP/HP
- At 220V — 3-Phase Motor Draws 2.5 AMP/HP
- At 110V — Single Phase Motor Draws 10 AMP/HP

Offer of Sale

The items described in this document and other documents and descriptions provided by Parker Hannifin Corporation, Hydraulics Group, and its authorized distributors ("Seller") are hereby offered for sale at prices to be established by Seller. This offer and its acceptance by any customer ("Buyer") shall be governed by all of the following Terms and Conditions. Buyer's order for any item described in its document, when communicated to Seller verbally, or in writing, shall constitute acceptance of this offer. All goods or work described will be referred to as "Products".

1. Terms and Conditions. Seller's willingness to offer Products, or accept an order for Products, to or from Buyer is expressly conditioned on Buyer's assent to these Terms and Conditions and to the terms and conditions found on-line at www.parker.com/saleterms/. Seller objects to any contrary or additional term or condition of Buyer's order or any other document issued by Buyer.

2. Price Adjustments; Payments. Prices stated on the reverse side or preceding pages of this document are valid for 30 days. After 30 days, Seller may change prices to reflect any increase in its costs resulting from state, federal or local legislation, price increases from its suppliers, or any change in the rate, charge, or classification of any carrier. The prices stated on the reverse or preceding pages of this document do not include any sales, use, or other taxes unless so stated specifically. Unless otherwise specified by Seller, all prices are F.O.B. Seller's facility, and payment is due 30 days from the date of invoice. After 30 days, Buyer shall pay interest on any unpaid invoices at the rate of 1.5% per month or the maximum allowable rate under applicable law.

3. Delivery Dates; Title and Risk; Shipment. All delivery dates are approximate and Seller shall not be responsible for any damages resulting from any delay. Regardless of the manner of shipment, title to any products and risk of loss or damage shall pass to Buyer upon tender to the carrier at Seller's facility (i.e., when it's on the truck, it's yours). Unless otherwise stated, Seller may exercise its judgment in choosing the carrier and means of delivery. No deferment of shipment at Buyers' request beyond the respective dates indicated will be made except on terms that will indemnify, defend and hold Seller harmless against all loss and additional expense. Buyer shall be responsible for any additional shipping charges incurred by Seller due to Buyer's changes in shipping, product specifications or in accordance with Section 13, herein.

4. Warranty. Seller warrants that the Products sold hereunder shall be free from defects in material or workmanship for a period of eighteen months from the date of delivery to Buyer. The prices charged for Seller's products are based upon the exclusive limited warranty stated above, and upon the following disclaimer: **DISCLAIMER OF WARRANTY: THIS WARRANTY COMPRISES THE SOLE AND ENTIRE WARRANTY PERTAINING TO PRODUCTS PROVIDED HEREUNDER. SELLER DISCLAIMS ALL OTHER WARRANTIES, EXPRESS AND IMPLIED, INCLUDING MERCHANTABILITY AND FITNESS FOR A PARTICULAR PURPOSE.**

5. Claims; Commencement of Actions. Buyer shall promptly inspect all Products upon delivery. No claims for shortages will be allowed unless reported to the Seller within 10 days of delivery. No other claims against Seller will be allowed unless asserted in writing within 60 days after delivery or, in the case of an alleged breach of warranty, within 30 days after the date within the warranty period on which the defect is or should have been discovered by Buyer. Any action based upon breach of this agreement or upon any other claim arising out of this sale (other than an action by Seller for any amount due to Seller from Buyer) must be commenced within thirteen months from the date of tender of delivery by Seller or, for a cause of action based upon an alleged breach of warranty, within thirteen months from the date within the warranty period on which the defect is or should have been discovered by Buyer.

6. LIMITATION OF LIABILITY. UPON NOTIFICATION, SELLER WILL, AT ITS OPTION, REPAIR OR REPLACE A DEFECTIVE PRODUCT, OR REFUND THE PURCHASE PRICE. IN NO EVENT SHALL SELLER BE LIABLE TO BUYER FOR ANY SPECIAL, INDIRECT, INCIDENTAL OR CONSEQUENTIAL DAMAGES ARISING OUT OF, OR AS THE RESULT OF, THE SALE, DELIVERY, NON-DELIVERY, SERVICING, USE OR LOSS OF USE OF THE PRODUCTS OR ANY PART THEREOF, OR FOR ANY CHARGES OR EXPENSES OF ANY NATURE INCURRED WITHOUT SELLER'S WRITTEN CONSENT, EVEN IF SELLER HAS BEEN NEGLIGENT, WHETHER IN CONTRACT, TORT OR OTHER LEGAL THEORY. IN NO EVENT SHALL SELLER'S LIABILITY UNDER ANY CLAIM MADE BY BUYER EXCEED THE PURCHASE PRICE OF THE PRODUCTS.

7. Contingencies. Seller shall not be liable for any default or delay in performance if caused by circumstances beyond the reasonable control of Seller.

8. User Responsibility. The user, through its own analysis and testing, is solely responsible for making the final selection of the system and Product and assuring that all performance, endurance, maintenance, safety and warning requirements of the application are met. The user must analyze all aspects of the application and follow applicable industry standards and Product information. If Seller provides Product or system options, the user is responsible for determining that such data and specifications are suitable and sufficient for all applications and reasonably foreseeable uses of the Products or systems.

9. Loss to Buyer's Property. Any designs, tools, patterns, materials, drawings, confidential information or equipment furnished by Buyer or any other items which become Buyer's property, may be considered obsolete and may be destroyed by Seller after two consecutive years have elapsed without Buyer placing an order for the items which are manufactured using such property. Seller shall not be responsible for any loss or damage to such property while it is in Seller's possession or control.

10. Special Tooling. A tooling charge may be imposed for any special tooling, including without limitation, dies, fixtures, molds and patterns, acquired to manufacture Products. Such special tooling shall be and remain Seller's property notwithstanding payment of any charges by Buyer. In no event will Buyer acquire any interest in apparatus belonging to Seller which is utilized in the manufacture of the Products, even if such apparatus has been specially converted or adapted for such manufacture and notwithstanding any charges paid by Buyer. Unless otherwise agreed, Seller shall have the right to alter, discard or otherwise dispose of any special tooling or other property in its sole discretion at any time.

11. Buyer's Obligation; Rights of Seller. To secure payment of all sums due or otherwise, Seller shall retain a security interest in the goods delivered and this agreement shall be deemed a Security Agreement under the Uniform Commercial Code. Buyer authorizes Seller as its attorney to execute and file on Buyer's behalf all documents Seller deems necessary to perfect its security interest. Seller shall have a security interest in, and lien upon, any property of Buyer in Seller's possession as security for the payment of any amounts owed to Seller by Buyer.

12. Improper Use and Indemnity. Buyer shall indemnify, defend, and hold Seller harmless from any claim, liability, damages, lawsuits, and costs (including attorney fees), whether for personal injury, property damage, patent, trademark or copyright infringement or any other claim, brought by or incurred by Buyer, Buyer's employees, or any other person, arising out of: (a) improper selection, improper application or other misuse of Products purchased by Buyer from Seller; (b) any act or omission, negligent or otherwise, of Buyer; (c) Seller's use of patterns, plans, drawings, or specifications furnished by Buyer to manufacture Product; or (d) Buyer's failure to comply with these terms and conditions. Seller shall not indemnify Buyer under any circumstance except as otherwise provided.

13. Cancellations and Changes. Orders shall not be subject to cancellation or change by Buyer for any reason, except with Seller's written consent and upon terms that will indemnify, defend and hold Seller harmless against all direct, incidental and consequential loss or damage. Seller may change product features, specifications, designs and availability with notice to Buyer.

14. Limitation on Assignment. Buyer may not assign its rights or obligations under this agreement without the prior written consent of Seller.

15. Entire Agreement. This agreement contains the entire agreement between the Buyer and Seller and constitutes the final, complete and exclusive expression of the terms of the agreement. All prior or contemporaneous written or oral agreements or negotiations with respect to the subject matter are herein merged.

16. Waiver and Severability. Failure to enforce any provision of this agreement will not waive that provision nor will any such failure prejudice Seller's right to enforce that provision in the future. Invalidation of any provision of this agreement by legislation or other rule of law shall not invalidate any other provision herein. The remaining provisions of this agreement will remain in full force and effect.

17. Termination. This agreement may be terminated by Seller for any reason and at any time by giving Buyer thirty (30) days written notice of termination. In addition, Seller may by written notice immediately terminate this agreement for the following: (a) Buyer commits a breach of any provision of this agreement (b) the appointment of a trustee, receiver or custodian for all or any part of Buyer's property (c) the filing of a petition for relief in bankruptcy of the other Party on its own behalf, or by a third party (d) an assignment for the benefit of creditors, or (e) the dissolution or liquidation of the Buyer.

18. Governing Law. This agreement and the sale and delivery of all Products hereunder shall be deemed to have taken place in and shall be governed and construed in accordance with the laws of the State of Ohio, as applicable to contracts executed and wholly performed therein and without regard to conflicts of laws principles. Buyer irrevocably agrees and consents to the exclusive jurisdiction and venue of the courts of Cuyahoga County, Ohio with respect to any dispute, controversy or claim arising out of or relating to this agreement. Disputes between the parties shall not be settled by arbitration unless, after a dispute has arisen, both parties expressly agree in writing to arbitrate the dispute.

19. Indemnity for Infringement of Intellectual Property Rights. Seller shall have no liability for infringement of any patents, trademarks, copyrights, trade dress, trade secrets or similar rights except as provided in this Section. Seller will defend and indemnify Buyer against allegations of infringement of U.S. patents, U.S. trademarks, copyrights, trade dress and trade secrets ("Intellectual Property Rights"). Seller will defend at its expense and will pay the cost of any settlement or damages awarded in an action brought against Buyer based on an allegation that a Product sold pursuant to this Agreement infringes the Intellectual Property Rights of a third party. Seller's obligation to defend and indemnify Buyer is contingent on Buyer notifying Seller within ten (10) days after Buyer becomes aware of such allegations of infringement, and Seller having sole control over the defense of any allegations or actions including all negotiations for settlement or compromise. If a Product is subject to a claim that it infringes the Intellectual Property Rights of a third party, Seller may, at its sole expense and option, procure for Buyer the right to continue using the Product, replace or modify the Product so as to make it noninfringing, or offer to accept return of the Product and return the purchase price less a reasonable allowance for depreciation. Notwithstanding the foregoing, Seller shall have no liability for claims of infringement based on information provided by Buyer, or directed to Products delivered hereunder for which the designs are specified in whole or part by Buyer, or infringements resulting from the modification, combination or use in a system of any Product sold hereunder. The foregoing provisions of this Section shall constitute Seller's sole and exclusive liability and Buyer's sole and exclusive remedy for infringement of Intellectual Property Rights.

20. Taxes. Unless otherwise indicated, all prices and charges are exclusive of excise, sales, use, property, occupational or like taxes which may be imposed by any taxing authority upon the manufacture, sale or delivery of Products.

21. Equal Opportunity Clause. For the performance of government contracts and where dollar value of the Products exceed \$10,000, the equal employment opportunity clauses in Executive Order 11246, VEVRRA, and 41 C.F.R. §§ 60-1.4(a), 60-741.5(a), and 60-250.4, are hereby incorporated.

North America

Industrial

USA

Chicago Region

Naperville, IL
Tel: (630) 964 0796

Great Lakes Region

Fairlawn, OH
Tel: (330) 670 2680

Northeast Region

Lebanon, NJ
Tel: (908) 236 4121

Pacific Region

Buena Park, CA
Tel: (714) 228 2509

Southern Region

Alpharetta, GA
Tel: (770) 619 9767

Canada

Milton, Ontario
Tel: (905) 693 3000

México

Toluca, Edo. de
México
Tel: (52) 72 2275 4200

Mobile

USA

Global Mobile

Lincolnshire, IL
Tel: (847) 821 1500

Central Region

Lincolnshire, IL
Tel: (847) 821 1500

Eastern Region

North Canton, OH
Tel: (330) 284 3355

Midwest Region

Hiawatha, IA
Tel: (319) 393 1221

Southern Region

Aledo, TX
Tel: (817) 441 1794

Western Region

Buena Park, CA
Tel: (714) 228 2509

Canada

Milton, Ontario
Tel: (905) 693 3000

México

Apodaca, N.L.
Tel: (52) 81 8156 6000

Truck

USA

Eastern Region

Cleveland, OH
Tel: (440) 519 1125

Western Region

San Ramon, CA
Tel: (925) 735 9573

Canada

Milton, Ontario
Tel: (905) 693 3000

México

Apodaca, N.L.
Tel: (52) 81 8156 6000

Europe

Austria

Wiener Neustadt
Tel: (43) 2622 23501 0

Belgium

Nivelles
Tel: (32) 67 280 900

Czech Republic and Slovakia

Klečany
Tel: (420) 284 083 111

Denmark

Ballerup
Tel: (45) 4356 0400

Finland

Vantaa
Tel: (358) 20 753 2500

France

Contamine-sur-Arve
Tel: (33) 4 50 25 80 25

Germany

Kaarst
Tel: (49) 2131 4016 0

Greece

Athens
Tel: (30) 210 933 6450

Hungary

Budapest
Tel: (36) 1 220 4155

Ireland

County Dublin, Baldonnell
Tel: (353) 1 466 6370

Italy

Corsico, Milano

Tel: (39) 02 45 19 21

The Netherlands

Oldenzaal
Tel: (31) 541 585000

Norway

Ski
Tel: (47) 64 91 10 00

Poland

Warsaw
Tel: (48) 22 57 32400

Portugal

Leca da Palmeira
Tel: (351) 22 999 7360

Romania

Bucharest
Tel: (40) 21 252 1382

Russia

Moscow
Tel: (7) 495 580 9145

Slovenia

Novo Mesto
Tel: (386) 7 337 6650

Spain

Madrid
Tel: (34) 91 675 7300

Sweden

Spanga
Tel: (46) 8 597 95000

Ukraine

Kiev
Tel: (380) 44 494 2731

United Kingdom

Warwick,
Tel: (44) 1926 317878

Asia Pacific

Australia

Castle Hill
Tel: (61) 2 9634 7777

China

Beijing
Tel: (86) 10 6561 0520

Shanghai

Tel: (86) 21 5031 2525

Hong Kong

Tel: (852) 2428 8008

India

Mahape, Navi Mumbai

Tel: (91) 22 5613 7081

Korea

Seoul
Tel: (82) 2 559 0400

Malaysia

Subang Jaya
Tel: (60) 3 5638 1476

New Zealand

Mt. Wellington
Tel: (64) 9 574 1744

Japan

Tokyo
Tel: (81) 3 6408 3900

Singapore

Jurong Town
Tel: (65) 6 887 6300

Taiwan

Taipei
Tel: (886) 2 2298 8987

Thailand

Bangkok
Tel: (662) 717 8140

Middle East

United Arab Emirates

Abu Dhabi
Tel: (971) 2 678 8587

Latin America

Pan American Division

Miami, FL
Tel: (305) 470 8800

Argentina

Buenos Aires
Tel: (54) 33 2744 4129

Brazil

Cachoeirinha RS
Tel: (55) 51 3470 9144

Venezuela

Caracas
Tel: (58) 212 238 5422

Africa

South Africa

Kempton Park
Tel: (27) 11 961 0700

